

CITY OF KENT

MULTIFAMILY DESIGN GUIDELINES



Ordinance No. 4225

Adopted by the City Council of Kent, Washington | December 13, 2016



CITY OF KENT

MULTIFAMILY DESIGN GUIDELINES

The City would like to acknowledge and thank those who contributed to the Multifamily Design Guidelines. In addition to those listed below, numerous individuals provided insight, expertise, and other contributions that informed this project.

Mayor

Suzette Cooke

Chief Administrative Officer

Derek Matheson

City Council

Dana Ralph, President

Jim Berrios

Bill Boyce

Brenda Fincher

Dennis Higgins

Deborah Ranniger

Les Thomas

Economic and Community Development

Hayley Bonsteel

Charlene Anderson

Matt Gilbert

Erin George

Kurt Hanson

Sharon Clamp

Jay Garnham

Katie Graves

Contributors:

Makers Architecture and Urban Design LLP – John Owen

Office of the City and GGLO – Dave Cutler

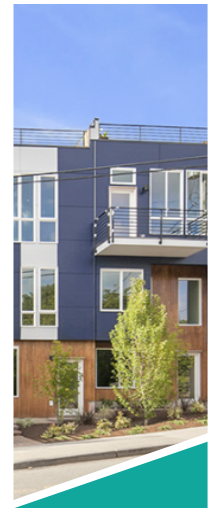

ACKNOWLEDGMENTS



General Objectives.....3

Applicability, Exemptions and Departures4

SITE DESIGN

I. Project Frontage 7
II. Vehicles and Parking 9
III. Pedestrian Circulation..... 10
IV. Setbacks and Privacy..... 11
V. Open Space 12
VI. Lighting..... 14
VII. Safety and Security..... 15
VIII. Dumpsters, Utilities and Service Areas 17

BUILDING DESIGN

IX. Architectural Design 21
X. Architectural Details..... 26
XI. Blank Walls..... 28
XII. Materials 29



GENERAL OBJECTIVES

- Meet the Comprehensive Plan Land Use Element Goal to revise development regulations to encourage multifamily development that is more flexible and innovative in terms of building design, street standards for private roads and site design.
- Contribute to attractiveness and usefulness of the public realm.
- Increase the overall durability, construction quality and attractiveness of multifamily development, as viewed by the public.
- Increase Kent's standing in the region as a desirable place to live.
- Increase pedestrian interest and activity, by facilitating pedestrian access to gathering places, services and other amenities.

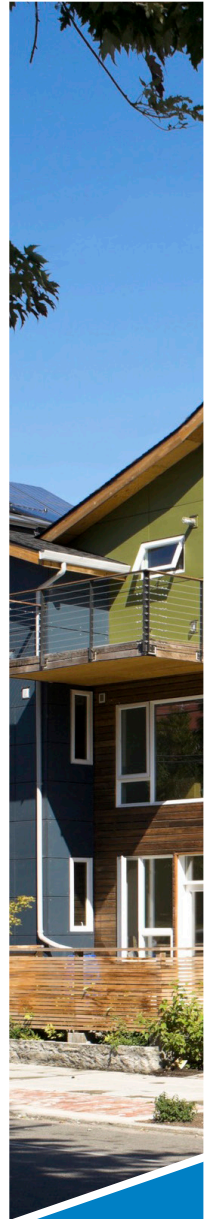

APPLICABILITY, EXEMPTIONS AND DEPARTURES

APPLICABILITY

The guidelines apply to:

- All new multifamily structures and development,
- Additions to existing buildings that increase gross floor area by 1,000 square feet or more, require conformance for the new portion of the structure and the area of the site that must be modified as a result of the expansion (this could include walkways, driveways, parking, signage), and
- Significant exterior modifications such as façade changes, windows, awnings, signage, etc.

HOW TO USE

Most sections include the following elements:

- Intent statements, which are overarching objectives,
- The use of words such as “shall,” “must,” and “is/are required,” signifying required actions,
- The use of the word “should” means that the provision is required unless there is a compelling reason to the contrary,
- The use of words such as “is/are recommended,” signifying voluntary measures, and
- Exceptions, which allow for flexibility to accommodate site-specific issues while still requiring the design to meet the intent of the design guidelines.

EXEMPTIONS

The following projects are exempted from the provisions of these guidelines:

- Projects within subareas that have their own guidelines (e.g., Downtown, Midway),
- Construction underground, which will not leave any permanent structure that extends above the surface after completion,
- Utilities in the public right-of-way,
- Repair and maintenance work on buildings, landscaping (including relatively minor replacement of plants and trees), or grounds (including parking lots), which does not significantly alter the appearance or function of the building, landscaping, or grounds (e.g., window replacement of less than 50% of the windows facing a public right of way),
- Interior remodeling work,
- Temporary uses and structures as defined in Kent City Code 15.02.534.

RELATION TO OTHER KENT CITY CODE (KCC) SECTIONS:

These guidelines augment other provisions in the KCC. The guidelines do not automatically supersede other KCC provisions. In the case of apparent conflict between these guidelines and other KCC provisions, the Administrator shall determine the applicability of these guidelines based on the objectives of public health, safety, welfare, direction from the Comprehensive Plan and the intent of the guidelines.

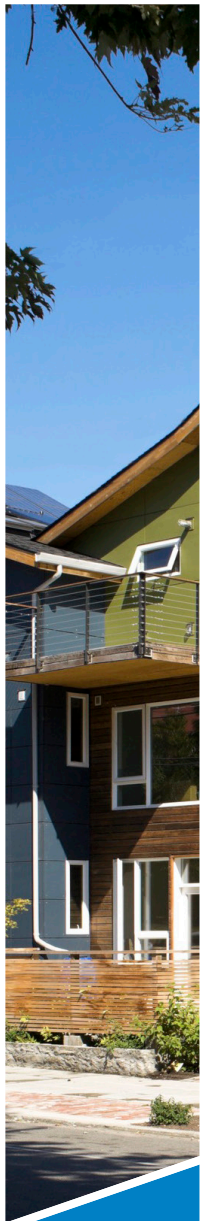



DEPARTURES:

The Administrator may approve, with respect to the guidelines, an application that varies (or “departs”) from the strict language of the guidelines provided that they find that the proposal meets the guidelines’ intent statements. If the Administrator approves a variation from the design requirements, such approval shall be based on the following findings:

- The application of certain provisions of the design guidelines would result in practical difficulties or unnecessary hardships inconsistent with the general purpose and intent of the underlying zone and of the design standards.
- Permitting a minor variation will not be materially detrimental to the public welfare or injurious to the property or improvements in the area.
- Permitting a minor variation will not be contrary to the objectives of the design guidelines.
- Such a variation is necessary because of special circumstances relating to the size, shape, topography, location or surroundings of the subject property that prevent strict adherence to certain design standards.
- The minor variation protects the integrity of a historic landmark or historic district.

NOTES:

- For projects on corner lots: the Administrator shall determine which street is considered “primary” and all guidelines referring to streets are only applicable to the primary street.
- The term “decorative” does not necessarily mean ornate. The term is used to indicate a high level of architectural detail or craftsmanship (such as moldings, reveals, exceptional use of materials, artistic treatments, etc.).
- The term “Administrator” refers to the Current Planning Manager.
- The term “public area” refers to public or private roadways, pedestrian paths, parks, open spaces or other common spaces as defined in KCC 15.02.335.1.

SITE DESIGN



SITE DESIGN

I. PROJECT FRONTAGE

INTENT:

- Provide for an attractive and active relationship between the building and the street.
- Provide privacy and security to residents facing the street.
- Encourage social interaction between residents and pedestrians.
- Provide a comfortable and welcoming entry, visible from the sidewalk, and an attractive streetscape.
- Provide an inviting ground floor façade.

FOR ALL PROJECTS:

1. Provide individual unit entries at ground level (accessible from outside). Ground level unit entries can open onto the street or a courtyard or open space that opens to the street. The Administrator may allow other entry configurations (such as consolidated entries), provided the design meets the intent of this section.
 - a. To provide resident privacy and a transition between the public and private realm,** set the building back at least 10 feet from the public right-of-way or raise the ground floor living space at least three feet above the sidewalk or pathway grade (preferably both, as in Figure 1 below).
 - b. Entries must be accessible from the street or interior open space.** Configurations where enclosed rear yards back up to a street are prohibited.
 - c. Individual pedestrian entries must be emphasized** by using all of the following:
 - i. Provide a porch, at least 24 square feet, or other architectural weather protection that provides cover for a person entering the unit and a transitional space between outside and inside the dwelling.
 - ii. Provide a planted area in front of each pedestrian entry of at least 20 square feet in area, with no dimension less than three feet. Provide a combination of shrubs, groundcover or trees.
 - iii. Set the garage door (if applicable) at least five feet farther from the street than the primary street-facing façade.

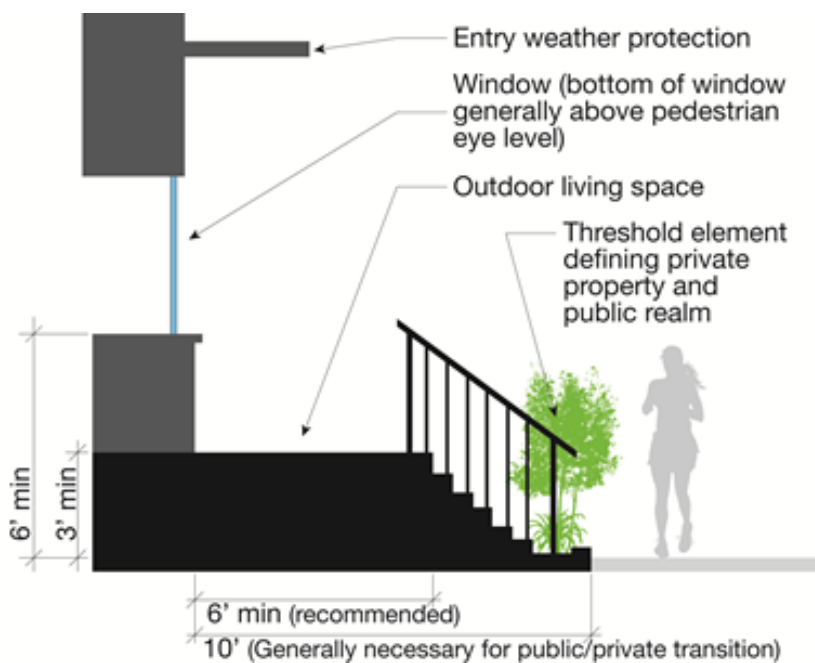

Figure 1. A combination of low fences or landscaping and porches, stoops, or patios define the transition from public to private space.



SITE DESIGN PROJECT FRONTAGE

- d. For projects with individual garages**, vehicle access to ground floor units shall be from an alley if one exists. For any configuration where primary pedestrian access is off the same façade as vehicular access, developments shall incorporate single-width parking configurations for at least 50 percent of the units (to minimize the impact of garage doors on the pedestrian environment). A pedestrian entry shall be provided that is separate from the garage door.
2. Surface parking shall not be located between the building and the street. (If multiple buildings, this only applies to the building(s) abutting the street.)
 3. Structured parking shall not constitute the entire frontage of any street-adjacent building. Structured parking must be screened per Vehicles and Parking (section II, page 9).
 - a. For corner properties with structured parking, provide a minimum of 15 feet from the corner along the primary street frontage in an active use. For non-corner properties, provide a minimum of 15 feet anywhere along the street frontage in an active use.
 - i. Active uses can include lobbies, entrances, gyms or fitness centers, meeting rooms and other similar spaces. Active use spaces may not contain mail rooms, storage, or any unsightly use (as determined by the Administrator).
 - ii. Active uses must be visible through transparent window areas over the entire 15 feet of the ground floor façade between two feet and eight feet above grade. The windows must look into the building's interior.
 4. If property is within ¼ mile of a bus stop or public park, provide convenient pathways or entries to facilitate access to these amenities for residents.
 5. Integrate weather protection, gutters and downspouts into the design of the structure as a whole.
 6. Limit the length of at-grade building façade and walls without openings (windows or doors) to 15 feet.
 7. Fencing or walls above four feet high are not allowed in the front yard or between the principal façade/entry and the sidewalk or public street. The Administrator may allow walls above four feet in height to accommodate steep topography. Chain link fences are not allowed in the front yard or between the primary building and a public right-of-way (excluding alleys).
 8. For projects approved by the Administrator for consolidated entries, enhance the building's presence and optimize interaction with the public sidewalk and rights-of-way through use of at least two of the following:
 - a. Pergolas or arbors
 - b. See-through gates or fences (excluding chain link)
 - c. Outdoor terraces or gardens that are designed to promote use (i.e., with benches or other pedestrian furniture or features)
 - d. High quality entry path materials such as special paving, tile, etc.
 - e. Balconies facing street



Figure 2. Good and bad examples of garage/entry configurations. The left example features a landscaped area and stoop to enhance the entry. The townhouses in the middle photo tuck the garages under the living units to reduce their visibility (note that this is a private roadway). In the right image, the lack of landscaping is a glaring omission, and is not acceptable.

II. VEHICLES AND PARKING

INTENT:

- Diminish and soften the visual impact of pavement and parked cars from the street and adjacent properties.
- Increase pedestrian safety and vehicular circulation in parking areas.

SURFACE PARKING

All projects with surface parking must adhere to the following in the design of parking lots and on-site vehicular circulation:

1. Surface parking shall be located to the rear of street-adjacent buildings. Alternatively, surface parking may be provided to the side of street-adjacent buildings, but not on a corner. A maximum of 60 linear feet of surface parking is permitted adjacent to the street.
2. Provide designated pedestrian pathways from public sidewalks and through surface parking areas to site destinations such as building entries and rear parking areas. Generally, walkways must be provided at least every four rows of parking or at least every 130 feet, whichever is less. Align the pathways to connect with major building entries or other sidewalks, pathways and destinations.
3. Minimize the width and extent of driveways in the front yards and visible from the street. The Administrator may determine the location and size of the driveway entrance (curb cut) to maximize safety and minimize impacts to pedestrian and bicycle movement.
4. Vehicular ingress and egress shall be from an alley, where one exists. The second choice of access (if no alleys exist) shall be from the street with less traffic, as determined by the Administrator. The third most desirable access choice is collector streets, and arterial streets are the fourth and least desirable choice for vehicular ingress and egress.
5. Where there are significant changes in elevation, utilize topography to reduce the visibility of parking from public areas and adjacent properties.

STRUCTURED PARKING

All projects must adhere to the following in the design of structured parking:

1. Structured parking may not constitute the entire frontage of any street-adjacent building. See Project Frontage (section I, page 7) for frontage requirements related to structured parking.
2. Locate structured parking to minimize visual impact to residences and public streets. Ensure parking structures visible from public streets are architecturally compatible with the main structure, and provide building and finish elements that create visual interest to the streetscape, such as artwork or grillwork.
3. Where structured parking is adjacent to the sidewalk or within 10 feet of the sidewalk edge, the façade shall incorporate a combination of artwork, grillwork, special building material or other treatment/design that enhances the pedestrian environment. Small setbacks with terraced landscaping elements can be particularly effective in softening the appearance of structured parking.
4. Parking facilities shall be well-lit for safety with non-glare lighting to reduce impacts to adjacent uses. See Lighting (section VI, page 14) for lighting level standards.



Figure 3. Examples of structured parking showing screening techniques, minimized visual impact and enhanced pedestrian environment.

III. PEDESTRIAN CIRCULATION

INTENT:

- Provide convenient, safe and attractive pedestrian routes.
- Increase social interaction.

FOR ALL PROJECTS:

1. Pedestrian walks shall be separated from residential structures by at least three feet for landscaping. The Administrator may consider other treatments to provide attractive pathways. Examples include mosaic, bas-relief artwork, or other decorative treatments that meet the intent of the guidelines. (Figure 4 provides examples.)
2. Where not visible to the public (i.e., on the interior of the site), all paths shall be a minimum of five feet in width.
3. Public pathways must be compliant with the Americans with Disabilities Act (ADA).



Figure 4. Photo on left shows landscaping between walkways. Photo on right shows wall treatment to provide interest.



IV. SETBACKS AND PRIVACY

INTENT:

- Provide privacy for residents, especially those immediately adjacent to the proposed development.
- Protect light and air access for residents of proposed development as well as residents in adjacent existing structures.

FOR ALL PROJECTS:

Design project to reduce intrusion and impacts to adjacent and nearby properties through meeting all of the following:

1. Offset window placement to avoid direct sightlines between living spaces.
2. Orient courtyards and balconies to maximize privacy.
3. Landscape all setbacks with a combination of landscape, hardscape or other amenities.
4. Shape upper levels to increase solar access, light, and air to adjacent lower structures, on- and off-site open spaces, and adjoining residential land uses.

FOR PROJECTS WITH LOT LINES ABUTTING AN EXISTING SINGLE-FAMILY ZONE:

Abutting an existing single-family zone: Provide an appropriate transition or complement to adjacent single-family zones. Projects shall create a step in perceived height, bulk or scale between the anticipated development potential of the adjacent single-family zone and the the proposed development. This can be done through any of the following:

1. Increasing the distance from the building to the edge of the single-family zone.
 - a. Set building back from interior or rear lot lines abutting single-family zones a minimum of 2 feet for every 10 feet in height.
2. Providing shading or increased landscape buffer at the edge of a single-family zone.
3. Stepping back upper floors so building height/mass is less intense near single-family zone.
4. Matching the scale of adjacent single-family zone developments in building detailing.

The Administrator may consider other strategies to provide attractive and effective transitions between single-family zones and multifamily development.



V. OPEN SPACE

INTENT:

- Add to the livability of new residences.
- Provide visual interest and relief.
- Provide opportunities for outdoor activities.
- Provide light and air in a new residential development.
- Provide opportunities for social interaction.

FOR ALL PROJECTS

All projects must provide 150 square feet of on-site open space per dwelling unit. Acceptable types of open space include:

a. Common outdoor open space

Where accessible to all residents, common outdoor open space may count for up to 100 percent of the required open space. Common outdoor open space includes landscaped courtyards, shared decks, gardens with pathways, children’s play areas, pools, water features, accessible (un-fenced) areas used for stormwater retention or other multipurpose recreational or green spaces to which all residents have access. Special requirements for common open spaces include the following:

- Required setback areas shall not count toward the open space requirement unless they are part of an open space that meets the other requirements of common open space.
- Space shall have a minimum dimension of 15 feet in any direction to provide functional leisure or recreational activity. This dimension can be waived based on site conditions such as topography or irregular lot geometry.
- Space shall feature paths or walkable areas, landscaping, seating, lighting, play structures, sports courts or other pedestrian amenities to make the area more functional and enjoyable for a range of users, taking into consideration potential noise issues related to hard court sports such as basketball, tennis and handball.
- Common space shall be separated from ground level windows, streets, service areas and parking lots with landscaping, low-level decorative fencing (no chain link), or other treatments as approved by the Administrator that enhance safety and privacy for both the common open space and dwelling units.
- The space shall be oriented to receive sunlight and preferably face south, if possible. Open space may also face east or west, but not north, unless the Administrator determines that site conditions such as topography or irregular lot geometry warrant waiving this requirement.
- The space must be accessible from the dwelling units. Ideally, it should be centrally located, if practical. The space must be oriented to encourage activity from local residents.



Figure 5. Good examples of common open space, including street level courtyards (left) and a network of open spaces with a children’s play area and a pedestrian corridor (right).



- b. Balconies
Individual balconies or patios (not including covered porches or stoops) may be used for up to 25 percent of the required open space. To qualify as open space, balconies or patios must be at least 40 square feet, with no dimension less than five feet.
- c. Rooftop decks and terraces
Rooftop decks and terraces may be used to meet up to 50 percent of the required open space, provided the following conditions are met:
- Space must be accessible to all dwelling units and ADA compliant.
 - Space must provide amenities such as seating areas, barbeques, fireplaces, recreational spaces, landscaping, etc.
 - Space must feature surfacing which enables residents to use the open space.
 - Space must incorporate features that provide for the safety of residents, such as appropriate lighting levels. See Safety and Security (section VII, page 15).
- d. On-site indoor recreation areas
Indoor recreation areas may be used to meet up to 25 percent of the required open space provided the following conditions are met:
- Space must be ADA accessible to all dwelling units.
 - Space is designed for and includes equipment for recreational uses, preferably for a range of users.
- e. Sensitive or critical areas
Sensitive areas shall only count toward open space requirements if integrated into the site design to be visible and usable by residents with features such as trails and benches. Sensitive or critical areas meeting these requirements may count for up to 50 percent of the required open space, but only the space utilized by the built amenities or trails, including a five-foot radius around the amenities, shall be counted.



VI. LIGHTING

INTENT:

- Provide for personal safety and security.
- Reduce the adverse impacts of lighting and retain dark skies.

FOR ALL PROJECTS

All publicly accessible areas and areas commonly used by residents shall be lighted with levels as follows:

1. Areas of low pedestrian activity such as service areas and vehicular traffic areas: minimum 0.2 foot-candles (fc), maximum four fc.
2. Moderate or high volume pedestrian areas and building entries: minimum one fc, maximum five fc, preferred average two fc.
3. Public parking lots: minimum one fc, maximum four fc.

Additionally, all projects must meet the following:

1. Lighting shall be provided at consistent levels, with an average lighting level to minimum lighting level uniformity ratio no less than 3:1, to create gradual transitions between varying levels of lighting and between lit areas and unlit areas. Highly contrasting pools of light and dark areas shall be avoided.
2. Pedestrian lighting shall have a maximum height of 15 feet.
3. Parking area lighting fixtures shall be fully shielded, dark sky rated and mounted no more than 20 feet above the ground, with lower fixtures preferable so as to maintain a human scale.
4. Steady, non-flashing lighting of building features, artwork and special landscape elements may be allowed, subject to the findings of the Administrator that the light causes no significant adverse impact.
5. Provide lighting that complements the building and site design and provides for safe pedestrian circulation and gathering places while minimizing light spillage off-site.



VII. SAFETY AND SECURITY

INTENT:

- Increase personal safety and property-related security.

FOR ALL PROJECTS

In site planning and design, avoid the following:

1. Entrapment areas, where a person could become trapped with no exit route. Provide two means of egress from all outdoor spaces. Ensure entrapment conditions are avoided in the design of rooftop decks.
2. Areas that are dark or not visible from a public space or right-of-way.
3. Vegetation and fences that restrict visibility into occupiable open space, pathways and building entries.
4. Buildings, vegetation or other objects (e.g., a storage enclosure) that block visibility into a space or provide places to hide.
5. Screens or landscaping that block motorists' views of pedestrians crossing streets, driveways and vehicular circulation areas.

Where visibility is necessary to avoid creating an unsecure area to reduce the potential for pedestrian/vehicle collisions, do not plant vegetation that will obstruct views between three and eight feet above the ground.



Figure 6. Fences that prevent visibility from public ROW and open space can decrease security because criminal activity cannot be seen from the street.



IF AT ALL FEASIBLE, PROVIDE FOR:

1. "Passive surveillance"—the ability of people occupying buildings and public spaces to view all parts of accessible spaces.
2. Appropriate natural access control features that delineate where the general public should not enter without an invitation. For example, a low fence or hedge can indicate that people should not enter an open space except through a gate. Access control should not limit visibility of passive surveillance.
3. Defining territory, through indicating clearly what parts of the site are open to the public and what parts are not.

Additionally, design with maintenance in mind; well-maintained sites indicate that someone cares for the site and tend to discourage crime.



Figure 8. Passive surveillance, or the ability of people in buildings or traveling along roadways to see outdoor spaces, increases security.



Figure 9. This residential complex incorporates passive surveillance, territorial definition and good visibility and lighting to provide a more secure pathway and open space.



VIII. DUMPSTERS, UTILITIES AND SERVICE AREAS

INTENT:

- Minimize the visual, auditory and olfactory impacts of waste handling, storage areas, utilities and other similar facilities.
- Allow for the efficient movement of utility functions and servicing of buildings.

LOCATION AND DESIGN

The visual, auditory, and olfactory impacts of waste handling, storage areas, utilities and similar activities and facilities shall be minimized. Reduce impacts of refuse containers and storage areas through all of the following measures:

1. Service areas (loading docks, trash dumpsters, compactors, recycling areas, electrical panels and mechanical equipment areas) shall be located to avoid negative visual, auditory (noise), olfactory or physical impacts on the street environment and adjacent residentially zoned properties. The Administrator may require evidence that such elements will not significantly impact neighboring properties or public areas. (For example, the Administrator may require noise damping specifications for fans near residential zones.) Service areas shall be sited for alley access if available.
2. Service areas must not be visible from the sidewalk and adjacent properties. Where the Administrator finds that the only option for locating a service area is either visible from a public right-of-way or space or from an adjacent property, the area must be screened with either landscape or structural screening measures provided under "Screening" (below, this section).
3. Ground-mounted mechanical equipment must be located and screened to minimize visual and noise impacts to pedestrians on streets and adjoining properties.
4. Roof-mounted mechanical equipment must be located and screened so the equipment is not visible from the ground level of adjacent streets or properties within 20 feet of the structure. Match the color of roof mounted equipment with the exposed color of the roof to minimize visual impacts when equipment is visible from higher elevations nearby.

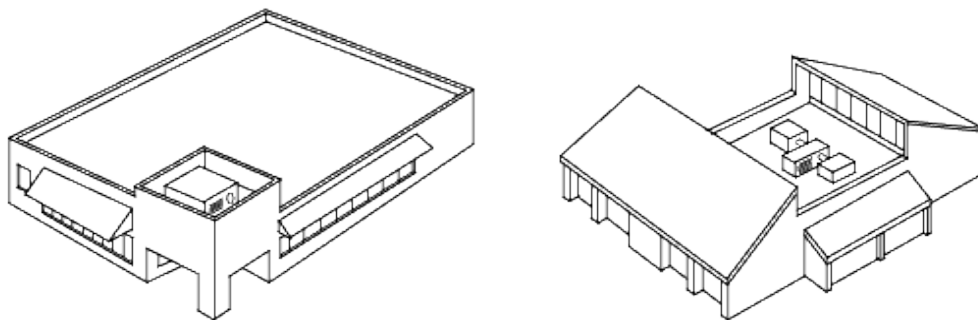

Figure 10. Examples of how to screen roof-mounted mechanical equipment.

5. Locate and screen utility meters, electrical conduit and other service and utilities apparatus so they are not visible from adjoining properties and nearby streets.
6. Other provisions of this section notwithstanding, service areas used by residents shall be located to avoid entrapment areas and other conditions where personal security would be compromised. The Administrator may require pedestrian-scaled lighting or other measures to enhance security.
7. Locate or shield noise producing mechanical equipment such as fans or heat pumps to meet state law provisions (WAC 173-60).



8. All service connections and on-site utilities including wires and pipes must be located underground. Meters may be attached to buildings. Project proponents are required to coordinate with the local electric utility provider to locate electrical service facilities in the least obtrusive way.



Figure 11. Place utility meters in less visible locations. Note that the example above is acceptable on a service alley but not near a street or residential walkway, whereas the example at left may be acceptable in a more visible location.



SITE DESIGN DUMPSTERS, UTILITIES AND SERVICE AREAS

SCREENING

Where screening of service areas is called for (where impacts cannot be adequately addressed through location or other means described above), adhere to the following:

1. A structural enclosure shall be constructed of masonry, heavy-gauge metal or decay-resistant composite wood, and have a roof. The walls must be sufficient to provide full screening from the affected roadway or use. The enclosure may use overlapping walls to screen dumpsters and other materials (see Figure 12, below). Gates shall be made of heavy-gauge, sight-obscuring material, and the enclosure shall be designed to be architecturally consistent and compatible with the architectural concept for the site or building it serves.
2. Collection points shall be located and configured so that the enclosure gate swing does not obstruct pedestrian or vehicle traffic, or does not require that a hauling truck project into any public right-of-way.
3. The service area shall be paved.
4. Weather protection of recyclables, trash and compost/yard waste shall be ensured by using weather-proof containers or by providing a roof over the storage area.
5. In addition to the required screening, artwork such as paint schemes or coverings that help to blend the equipment into the background may also be utilized.



Figure 12. Examples of acceptable dumpster enclosures and screening techniques.

BUILDING DESIGN



BUILDING DESIGN

IX. ARCHITECTURAL DESIGN

INTENT:

- Provide a welcoming entry to residential buildings.
- Provide a visually interesting roofline.
- Achieve architectural scale that is compatible with the size and visual massing of development envisioned within the zoning classification.
- Add visual interest and sense of quality and craftsmanship to building facades.
- Enhance the pedestrian experience.

DEFINITIONS:

Architectural scale

Perceived height and bulk of a building relative to that of neighboring buildings or anticipated future neighboring developments. A building has “good architectural scale” if its visual size is relatively similar to development that is planned for in the zoning classification.

Modulation

Stepping back or projecting forward of portions of a building face, within specified intervals of building width and depth, as a means of breaking up the apparent bulk of a structure’s continuous exterior walls.

Articulation

Visually enhancing a building façade by including features such as broken rooflines, chimneys, entrances, distinctive window patterns.

BUILDING ENTRY DESIGN

Principal building entrances of all buildings shall feature all of the following:

1. A minimum of 50 square feet of pedestrian weather protection. Entries may satisfy this requirement by being set back into the building façade.
2. Lighting, to conform to Lighting (section VI, page 14).
3. Building or business name and address number.
4. Transparency such as glass doors, windows or glazing (window area) near the door so that the visitor and occupant can view people opening the door from the other side (not required for individual unit entries leading directly to a single dwelling).
5. Security, to the extent feasible. Entries must be visible from areas with high pedestrian activity. See Safety and Security (section VII, page 15) for more details.
6. Architectural or artwork enhancements, including one or more of the following:
 - a. Ornamental doors or windows,
 - b. Ornamental paving or materials (e.g., decorative tile work),
 - c. Distinctive architectural lighting,
 - d. Artwork,
 - e. Landscaping, or
 - f. Adjacent usable open space.





Figure 13. Entrances enhanced by details and materials, complex architectural elements, site features and lettering.



ROOFLINE CHARACTER

All projects must provide a roofline design that fits with the character of the building and provides some level of visual interest. The upper level or top of the building should have a considered (intentional) treatment. This may be done in any of the following ways:

1. Design a shaped, sloped, pitched or varied roof form – visible to passersby from public areas including highways or other distant views.
2. Provide cornice expressions, eyebrows, overhangs, horizontal projections.
3. Increase variety of building massing at upper levels to establish contrast with overall bulk and mass of lower levels.
4. Incorporate extensions (chimneys, turrets, towers, skylights, clerestories – if logical continuation of architecture).
5. Utilize other height variations to complement adjacent structures.

Avoid superfluous or tack-on roof features such as mansard roof extensions, roof signs or roof ribs.

FAÇADE MODULATION AND BULK/MASS DESIGN.

All new buildings over three stories, over 5,000 square feet in gross building footprint or with façades longer than 100 feet measured horizontally along a public right-of-way or visible from a public right-of-way shall provide at least **three** major modulation or articulation features as described below along any façade that is visible from a public right-of-way, residential zone or pedestrian pathway. The “articulation interval” at which the repetitive element repeats should not be greater than 50 feet.

1. **Horizontal building modulation.** Horizontal modulation is the stepping back or extending forward of building stories or horizontal building elements. To satisfy this requirement through horizontal modulation, the depth (extension out or set back from the building facade) of the modulation must be at least two feet when tied to a change in the roofline and at least five feet in other situations. Balconies may be used to qualify for this option, provided they have a floor area of at least 40 square feet, are integrated with the architecture of the building, and project at least two feet from the building façade. Step backs of upper stories are a common form of horizontal modulation.



Figure 14. Buildings with modulation to increase interest and human scale. Vertical modulation on the upper left and lower left, horizontal modulation in the lower right, and a mix of both at upper right.



BUILDING DESIGN
ARCHITECTURAL DESIGN

2. **Vertical building modulation.** Vertical modulation is the extension or stepping back of vertical elements of a building. In order to satisfy this guideline through vertical modulation, the minimum depth of modulation is 18 inches and minimum width for each modulation is 15 feet. Balconies may not be used to meet this modulation option unless they are recessed or projected from the façade and integrated with the building’s architecture as determined by the Administrator.
3. **Modulated roofline.** Buildings may qualify for this option by modulating the roof line of all façades visible from a street, park or pedestrian pathway consistent with the following standards:
 - a. For flat roofs or façades with a horizontal fascia (the board at the end of a roof eave or cornice) or parapet, change the roofline so that there is a change of the roofline at least every 60 feet. Minimum vertical dimension of roof line modulation is two feet.
 - b. For gable, hipped or shed roofs, a slope of at least three feet vertical to 12 feet horizontal is required to meet the guideline.
 - c. Other roof forms such as arched, vaulted, dormer or saw-toothed may satisfy this design standard if the individual segments of the roof with no change in slope or discontinuity are less than 60 feet in width (measured horizontally).
4. **Repeating distinctive window patterns** at intervals less than the articulation interval.
5. **Providing a porch, patio, deck or covered entry** for each articulation interval.
6. **Changing the roofline** by alternating dormers, stepped roofs, gables, or changing roof textures on certain features such as metal roofs on towers and dormers to reinforce the modulation or articulation interval.
7. **Changing materials** with a change in building plane.
8. **Providing lighting fixtures, trellises, trees or other landscape feature** within each interval.
9. **Creating open-to-the-sky courtyards and terraces** that break the building façade.
10. **Incorporating projections** such as:
 - a. Window bays
 - b. Porch additions
 - c. Stair enclosures
 - d. Chimneys
 - e. Balconies
 - f. Recesses at windows, entries, doors or other openings
 - g. Minor projecting masses
11. **Using materials and colors to emphasize major or minor architectural scales,** to introduce sense of detail and create distinctions between structures.

The Administrator may increase or decrease the 60-foot interval for modulation and articulation to better match surrounding structures or to implement an adopted subarea plan.



Figure 15. Example of a distinctively designed roofline.





BUILDING DESIGN ARCHITECTURAL DESIGN

Figure 17. Examples of well-articulated buildings. Note how the window divisions, modulation, material variation and rooflines all serve to divide up the façade without disrupting the overall design. Note that distinctive window design meets the intent of the section without adhering strictly to the modulation guidelines in the bottom right photo.

IX. ARCHITECTURAL DETAILS

INTENT:

- Add visual interest to building appearance.
- Enhance the pedestrian experience.
- Contribute to public perception of Kent as a desirable place to live through showing care and craftsmanship in design.

FOR ALL PROJECTS

All new buildings shall include on the façades that face a public right-of-way at least **three** of the following design features:

1. Distinctive roofline treatments, such as an ornamental molding, or other roofline device visible from the ground level.
2. Special treatment of windows and doors, other than standard metal molding/framing details, around all ground floor windows and doors, decorative glazing or door designs.
3. Decorative building materials, such as decorative masonry, shingle, brick or stone.
4. Individualized patterns or continuous wood details, such as fancy butt shingles (a shingle with the butt end machined in some pattern, typically to form geometric designs), decorative moldings, brackets, trim or lattice work, ceramic tile, stone or similar materials. The applicant must submit architectural drawings and material samples for approval.
5. Use of green walls, planter boxes, landscaped trellises, wall trellises, decorative or special railings, grill work, landscape guards or specially designed canopies, as an integral part of the building's design.
6. Decorative artwork, which may be freestanding or attached to the building and may be in the form of mosaic mural, bas-relief sculpture, light sculpture, water sculpture, fountain, free standing sculpture, art in pavement or other similar artwork. Painted murals or graphics on signs or awnings do not qualify.
7. Special building elements, such as pilasters, entablatures, wainscots, canopies or marquees that exhibit nonstandard designs.

RESIDENTIAL WINDOW DETAILS

The façades of residential buildings shall employ techniques to recess or project individual windows above the ground floor at least two inches from the façade or incorporate window trim at least four inches in width that features color that contrasts with the base building color.

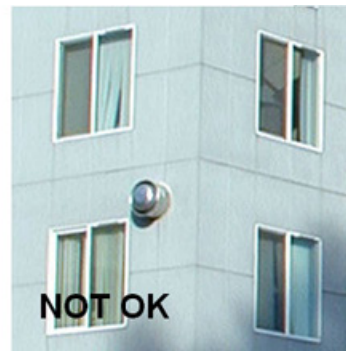
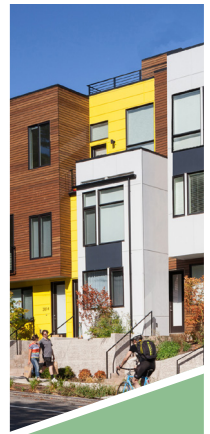

Figure 18. Acceptable (left and center examples) and unacceptable (right example) window treatments.





BUILDING DESIGN ARCHITECTURAL DETAILS

Figure 19. Examples of window and architectural detailing. Note that some examples (bottom right) meet the intent of adding visual interest to building appearance without strictly adhering to the guidelines.

XI. BLANK WALLS

INTENT:

- Improve the pedestrian experience near the building.
- Help ensure that the building does not detract from the character of its surroundings.

DEFINITION

For the purposes of these guidelines, a “blank wall” is any wall or portion of a wall that meets *either* of the following criteria:

- Has a surface area of 200 square feet of vertical surface without a window, door or building modulation or other architectural feature.
- Is over four feet in height from ground level and longer than 15 feet as measured horizontally without having a window, door, building modulation or other architectural feature.

FOR ALL PROJECTS

All blank walls within 50 feet of a public area or adjacent property and also visible from that public area or adjacent property, shall be treated in one or more of the following ways:

1. Install a vertical trellis in front of the wall with climbing vines or plant materials. For large blank wall areas, the trellis must be used in conjunction with other treatments described below.
2. Provide a landscaped planting bed or a raised planter bed in front of the wall. Plant materials shall be selected to obscure or screen at least 50 percent of the wall's surface within four years.
3. Provide artwork (mosaic, mural, sculpture, relief, etc.) over at least 50 percent of the blank wall surface.
4. Employ high quality building materials (such as brick) and provide desirable visual interest.
5. Special architectural lighting.



Figure 20. Artwork or a trellis can effectively treat a blank wall.



XI. MATERIALS

INTENT:

- Help ensure the quality and maintainability of new development.
- Help ensure attractiveness of new buildings.

FOR ALL PROJECTS

1. The following are allowed only with special detailing, as described below:
 - a. Metal siding.** When used as a siding material over more than 25 percent of a building's façade visible from a public area, metal siding must:
 - i. Have a matte finish in neutral or earth tone such as buff, gray, beige, tan, cream, white, or a dulled color, such as barn-red, blue-gray, burgundy, ochre.
 - ii. Include two or more of the following elements:
 1. Visible window and door trim painted or finished in a complementary color.
 2. Color and edge trim that cover exposed edges of the sheet metal panels.
 3. A base of masonry, stone or other approved permanent material extending up to at least two feet above grade that is durable. (The intent is to provide more durable materials near grade level.)
 - b. Concrete block walls.** Concrete block construction used over 25 percent of a building façade visible from a public area must be architecturally treated in one or more of the following ways:
 - i. Use of textured blocks with surfaces such as split face or grooved.
 - ii. Use of other masonry types, such as brick, glass block or tile in conjunction with concrete blocks.
 - iii. Use of decorative coursing to break up blank wall areas.
 - iv. Use of matching colored mortar where color is an element of architectural treatment for any of the options above.
 - c. Requirements for stucco, stucco-like and similar troweled finishes:**
 - i. To avoid deterioration, the finish material must be trimmed or sheltered from extreme weather by roof overhangs or other methods.
 - ii. The finish material may only be used in conjunction with other approved building materials.
2. Any material that is subject to damage and deterioration from human contact or landscape elements is prohibited within two vertical feet of the sidewalk or ground level or in areas that are especially subject to vandalism such as areas with low visibility. In these areas, a more durable finish material such as brick, concrete or concrete block shall be used.
3. Use of flat sheet materials such as fiber cement panels (e.g., HardiePanel) is not allowed on ground floor façades. This is because the panels do not provide human scale surfaces or textures or refined details. Textured panels on ground floors may be approved by the Administrator if they are detailed not to appear as a panelized system.



Figure 21. Examples of HardiePanel. This material is not allowed on ground floor façade, but in combination with other building materials (right) can be an effective exterior material above the ground floor.

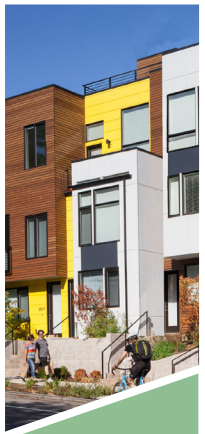

4. Prohibited materials for exterior of buildings (excluding special art features):
 - a. Mirrored glass.
 - b. Vinyl siding.
 - c. Corrugated fiberglass.
 - d. Chain link fencing within 50 feet of a building's public entrance (except for temporary purposes such as a construction site).
 - e. Crushed colored rock or tumbled glass.
 - f. Any sheet materials, such as wood or metal siding, with exposed edges or unfinished edges.
 - g. Any spray-on materials (e.g.: shot-crete) not specifically approved by the Administrator.
 - h. Non-durable materials subject to deterioration if exposed to weather such as most plastic and synthetic materials or materials that are particularly vulnerable to vandalism. Project applicants wishing to use synthetic materials must submit samples and product description information to the Administrator for approval. The Administrator will not accept such materials unless its durability and appropriateness is demonstrated.

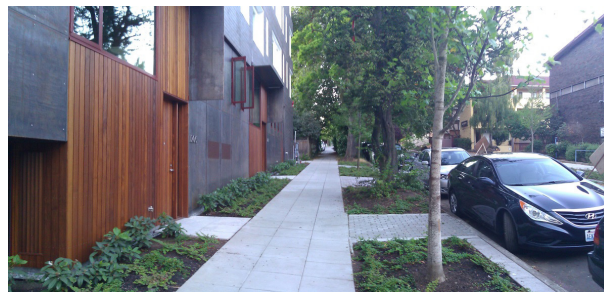

BUILDING DESIGN ARCHITECTURAL DETAILS

Figure 22. Examples of desirable materiality, including brick, glass, metal and steel.