

110 Ave SE

NOTES:

1. SEE STANDARD PLAN 6-84 FOR STREET NAME SIGN DETAILS.
2. PRIVATE STREET NAME SIGNS AND PRIVATE SIGN POSTS ARE MAINTAINED BY THE PROPERTY OWNERS.
3. "NO OUTLET" SIGNS SHALL HAVE AN ARROW SHOWING WHICH DIRECTION DOES NOT OUTLET.
4. CORNER BOLTS TO BE PART # TLO70M WITH PART # TLO62 JAM NUTS. DRIVE RIVETS TO BE PART # TL3806.

SQUARE METAL POST, SEE STANDARD PLAN 6-82a

9' MIN.
TO THE GROUND SURFACE

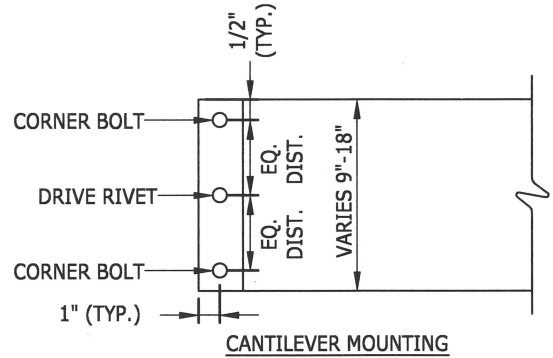

SIDEWALK FINISHED GRADE

2' MIN. CLEARANCE FROM FACE OF CURB
(10' MIN. CLEARANCE IF NO CURB) TO EDGE OF SIGN

ANCHOR AND FOUNDATION, SEE STANDARD PLAN 6-82a

CONCRETE BASE SHALL BE POURED IN PLACE AROUND ANCHOR WHILE PREVENTING CONCRETE FROM ENTERING THE ANCHOR

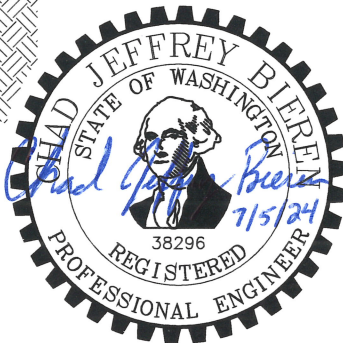

NOTE: THIS PLAN IS NOT A LEGAL ENGINEERING DOCUMENT BUT AN ELECTRONIC DUPLICATE. THE ORIGINAL, SIGNED BY THE ENGINEER AND APPROVED FOR PUBLICATION IS KEPT ON FILE AT THE CITY OF KENT. A COPY MAY BE OBTAINED UPON REQUEST.

		CITY OF KENT ENGINEERING DEPARTMENT	
		STREET NAME SIGN POST INSTALLATION	
DESIGNED	COK	SCALE	NONE
DRAWN	COK	DATE	5/2024
CHECKED	COK	ENGINEER	
APPROVED			
			STANDARD PLAN 6-83