

NOTES:

1. BICYCLE RACK TYPE 2 SHALL BE "NO SCRATCH" IN CIRCULAR OR TOFINO MULTI-RACK FROM SPORT WORKS, OR APPROVED EQUAL.
2. BICYCLE RACKS SHALL HAVE BEAD BLASTED FINISH.
3. INSTALL BICYCLE RACK SURFACE MOUNT, LEVEL AND PLUMB ACCORDING TO MANUFACTURER'S RECOMMENDED METHOD AND HARDWARE.
4. APPLIES TO BUFFER ZONES AT STREETScape TYPE C.
5. APPLIES TO BUFFER AND AMENITY ZONES AT STREETScape TYPES A AND B.
6. APPLIES TO BUFFER ZONES NEAR SIGNIFICANT INTERSECTIONS, MINOR INTERSECTIONS/CROSSINGS, AND MID-BLOCK CROSSINGS.

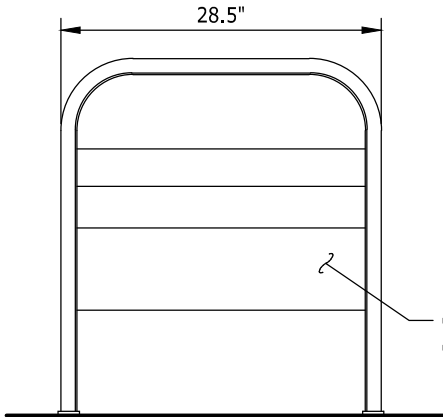

FRONT ELEVATION

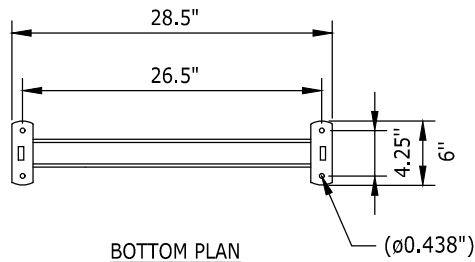

BOTTOM PLAN

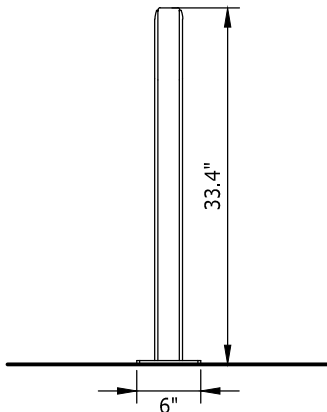

SIDE ELEVATION

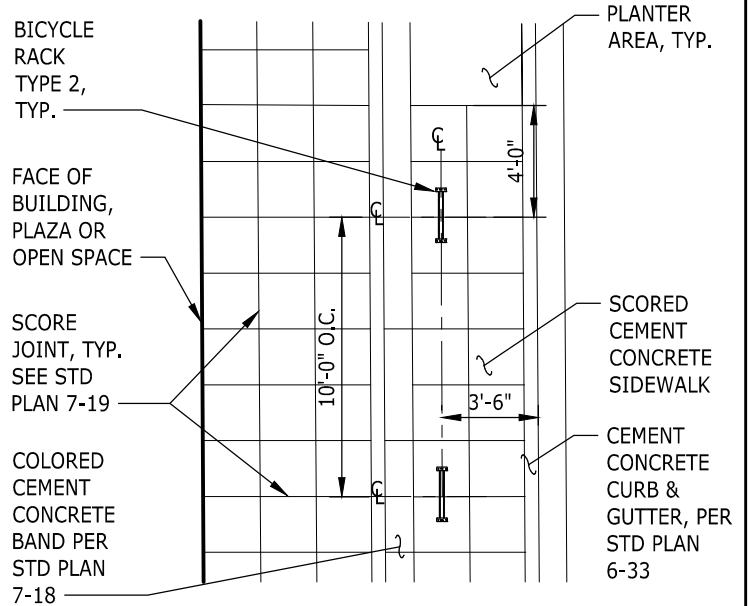

LAYOUT PLAN (NORTH SIDE & STREETScape TYPE C)

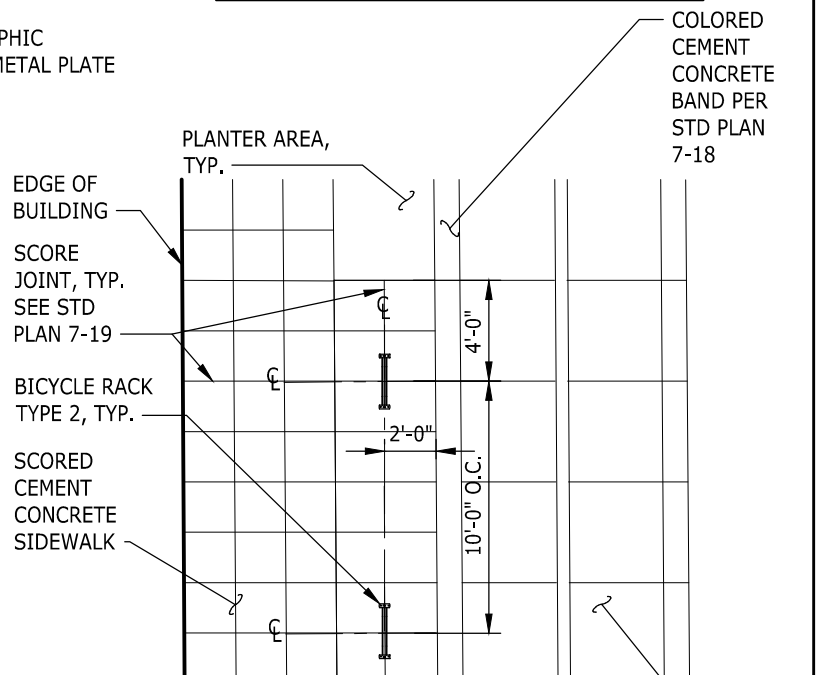

LAYOUT PLAN (SOUTH SIDE AT STREETScape TYPE A & B)

NOTE: THIS PLAN IS NOT A LEGAL ENGINEERING DOCUMENT BUT AN ELECTRONIC DUPLICATE. THE ORIGINAL, SIGNED BY THE ENGINEER AND APPROVED FOR PUBLICATION IS KEPT ON FILE AT THE CITY OF KENT. A COPY MAY BE OBTAINED UPON REQUEST.

		CITY OF KENT ENGINEERING DEPARTMENT	
		MEEKER STREET BICYCLE RACK TYPE 2	
DESIGNED: COK	SCALE: NONE	STANDARD PLAN	
DRAWN: COK	DATE: 8/2020	7-5	
CHECKED: COK	ENGINEER		
APPROVED:			