

NOTE: SEE KDCS 4.5.D

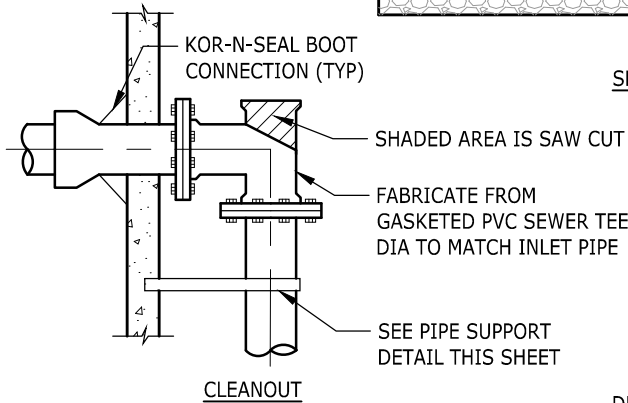

SECTION A-A

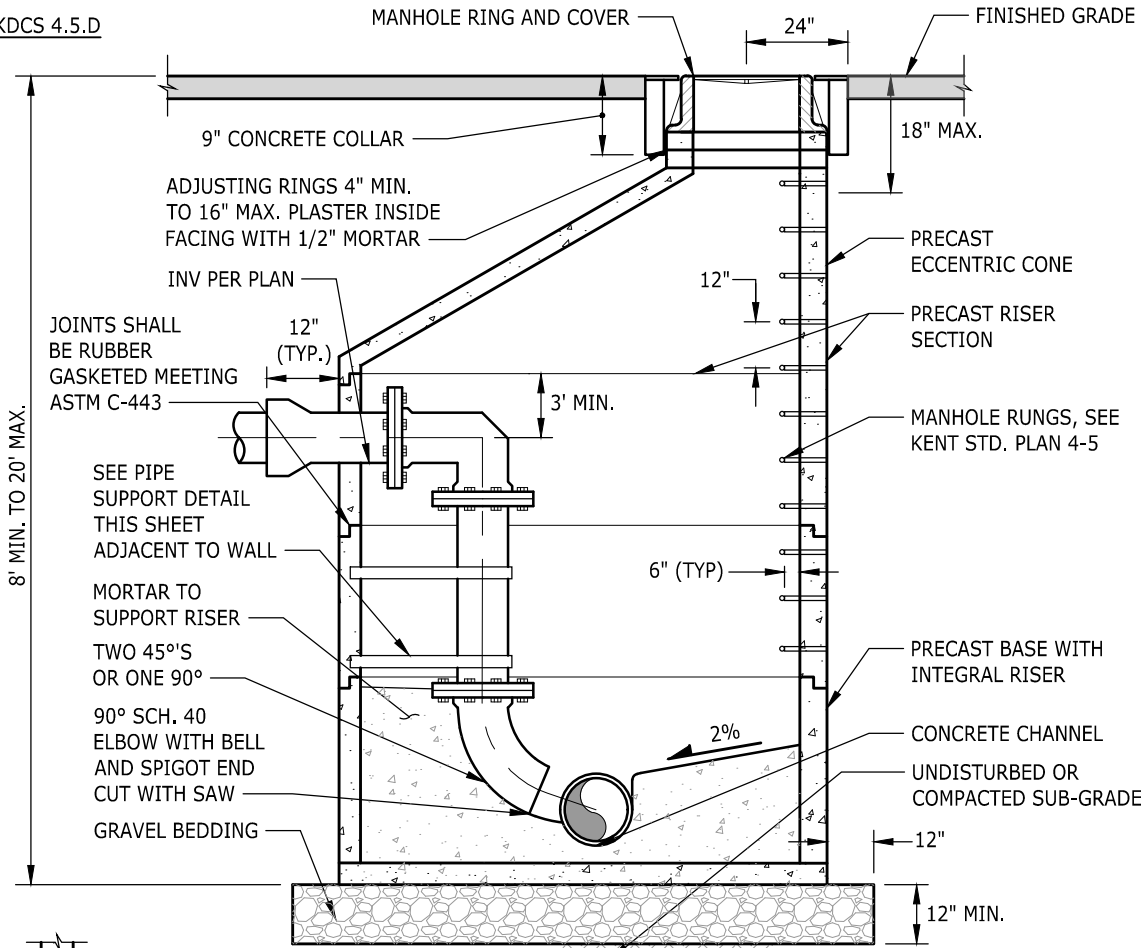
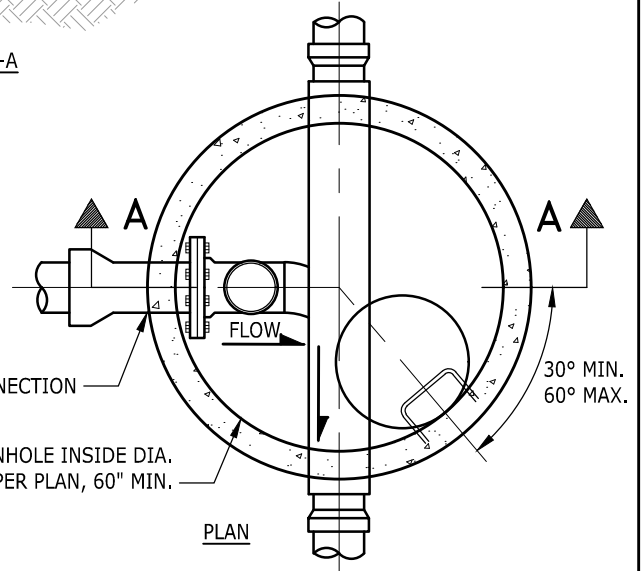

PLAN

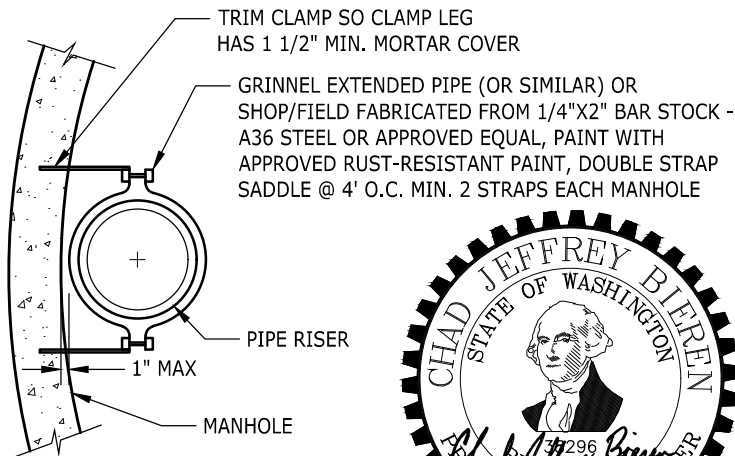

PIPE SUPPORT DETAIL



NOTE: THIS PLAN IS NOT A LEGAL ENGINEERING DOCUMENT BUT AN ELECTRONIC DUPLICATE. THE ORIGINAL, SIGNED BY THE ENGINEER AND APPROVED FOR PUBLICATION IS KEPT ON FILE AT THE CITY OF KENT. A COPY MAY BE OBTAINED UPON REQUEST.



**CITY OF KENT**  
ENGINEERING DEPARTMENT

**INSIDE DROP SANITARY SEWER  
MANHOLE**

DESIGNED	COK	SCALE	NONE	STANDARD PLAN
DRAWN	COK	DATE	9/2020	4-12
CHECKED	COK	ENGINEER		
APPROVED				