



LANDMARK REGISTRATION FORM **DRAFT 4/11/19**

PART I: PROPERTY INFORMATION

1. Name of Property

historic name: LUNAR ROVING VEHICLES
 other names/site number: Lunar Rovers; LRVs; Moon Buggies

2. Location

street address: Lunar Surface
 parcel no(s): See Physical Description & Figure 1
 legal description(s): See Physical Description & Figure 1

3. Classification

Ownership of Property:	Category of Property:	Name of related multiple property listing:
<input type="checkbox"/> private	<input type="checkbox"/> building(s)	(Enter "N/A" if property is not part of a multiple property listing.)
<input type="checkbox"/> public-local	<input type="checkbox"/> district	N/A
<input type="checkbox"/> public-State	<input type="checkbox"/> site	
<input checked="" type="checkbox"/> public-Federal	<input checked="" type="checkbox"/> structure	
	<input type="checkbox"/> object	

4. Property Owner(s)

name: National Aeronautics and Space Administration
 street: 300 E Street NW
 city: Washington state: DC zip: 20024

5. Form Prepared By

name/title: Sarah J. Martin / SJM Cultural Resource Services (3901 2nd Ave NE #202, Seattle, WA 98105)
 organization: Contracted consultant on behalf of the Kent Downtown Partnership (KDP) date: April 11, 2019

6. Nomination Checklist

- Site Map (REQUIRED)
- Photographs (REQUIRED): *please label or caption photographs and include an index*
- Last Deed of Title: *this document can usually be obtained for little or no cost from a title company*
- Continuation Sheets
- Other (please indicate):

PART II: PHYSICAL DESCRIPTION

7. Alterations

Check the appropriate box if there have been changes to plan, cladding, windows, interior features or other significant elements. These changes should be described specifically in the narrative section below.

- | | | | | | |
|------------------------------|--|--|------------------------------|--|---|
| <input type="checkbox"/> Yes | <input checked="" type="checkbox"/> No | Plan (i.e. no additions to footprint, relocation of walls, or roof plan) | <input type="checkbox"/> Yes | <input type="checkbox"/> No | Interior features (woodwork, finishes, flooring, fixtures) N/A |
| <input type="checkbox"/> Yes | <input type="checkbox"/> No | Cladding N/A | <input type="checkbox"/> Yes | <input checked="" type="checkbox"/> No | Other elements |
| <input type="checkbox"/> Yes | <input type="checkbox"/> No | Windows N/A | | | |

Narrative Description

Use the space below to describe the present and original (if known) physical appearance, condition, architectural characteristics, and the above-noted alterations (use continuation sheet if necessary).

The following narratives draw upon a rich assortment of archival and web-based primary and secondary sources, including historic photographs, drawings, first-hand accounts, government reports, press releases, newspaper accounts, film footage, and carefully selected published histories. The author wishes to thank John Little, assistant curator at the Museum of Flight, and Michael Lombardi, corporate historian at The Boeing Co., for their assistance.

It should be noted that this application builds on the precedent set by California and New Mexico, the first two states to include lunar objects and structures in their state historic registers. Both efforts involved the Apollo 11 Tranquility Base, where more than 100 objects and structures remain from the first manned exploration of the lunar surface. In 2010, the California State Historical Resources Commission and the New Mexico Cultural Properties Review Committee voted unanimously to add the many features at Tranquility Base to their respective state registers.¹

Introduction

The Lunar Roving Vehicle (LRV), commonly known as the lunar rover or Moon buggy, is history's first and only manned surface transportation system designed to operate on the Moon. At its Kent, Washington-based Space Center, the Boeing Company designed, tested, and built the four-wheeled vehicle for the National Aeronautics and Space Administration (NASA) to use in its Apollo J-class missions of 1971-72. Boeing, with its major subcontractor General Motors' Delco Electronics Division, delivered three assembled flight vehicles, one unassembled flight vehicle, and eight test units as part of its contract with NASA-Marshall Space Flight Center. Designed for the transport of two astronauts, their life support systems, and scientific equipment, the LRV allowed the astronauts to spend more time and travel greater distances on the lunar surface and to collect more scientific samples than in previous missions.

¹ Lucas Laursen, "The Moon Belongs to No One, but What About Its Artifacts?" Smithsonian.com, December 13, 2013, accessed Feb. 22, 2019, <https://www.smithsonianmag.com/science-nature/the-moon-belongs-to-no-one-but-what-about-its-artifacts-180948062/>

Locations and Settings

The three rovers used in Apollo missions 15, 16, and 17 remain on the lunar surface and have gone untouched since they were last used during their respective assignments. The vehicles are situated on the visible side of the Moon, an average of 238,855 miles away from Earth, in a harsh environment that lacks atmosphere and has extreme temperatures ranging from 260 to -280 degrees Fahrenheit (figure 1). The Moon has one-sixth the gravity of Earth, and a thin layer of fine, electrically charged dust covers the lunar surface.

The first LRV, Rover 1, is situated near the Apollo 15 landing site (26.13° N, 3.63° E) on the plains of Palus Putredinis adjacent to Hadley Rille near the Apennine Mountains (figures 1 through 8). This region is in the northeast quadrant of the visible face of the Moon. Hadley Rille is a distinctive and winding channel thought to have been created by ancient lava flow. The mountain closest to the landing site is Hadley Delta. NASA selected this landing site for its geological diversity, with the mountains, rille, hilly plains, and nearby crater clusters providing an area rich for scientific study.² Rover 1 traversed this area during three extravehicular activities (EVAs) between July 31 and August 2, 1971.

The **second LRV**, Rover 2, is located in the Descartes Highlands near the Apollo 16 landing site (-8.97° N, 15.50° E) on the Cayley Plains (figures 1, 9 through 14). This grooved, hilly region is in the southeast quadrant of the visible face of the Moon and includes several young craters that NASA considered ideal for exploration. The landing site is approximately 500 meters east of the rim of Spook Crater, with several other notable craters in proximity. The Descartes Mountains are south and east of the landing site.³ Rover 2 traversed this area during three EVAs between April 21 and 23, 1972.

The **third LRV**, Rover 3, resides near the Apollo 17 landing site (20.19° N, 30.77° E) in the Taurus-Littrow Highlands, a mountainous region in the northeast quadrant of the visible face of the Moon (figures 1, 15 through 24). The site is named for the Taurus Mountains and the Littrow Crater, located on the southeastern rim of the Serenitatis Basin. Three prominent rounded hills bound the landing site – South Massif, North Massif, and East Massif – with smaller “sculptured” hills to the northeast. The site afforded the opportunity to explore mountainous highlands, valley lowlands, craters, and a fault scarp.⁴ Rover 3 traversed this area during three EVAs between December 11 and 14, 1972.

² James R. Zimbelman, “The Apollo Landing Sites – Slide Set,” Lunar and Planetary Institute website, accessed December 28, 2018, <https://www.lpi.usra.edu/publications/slidesets/apollolandings/>. Also, National Aeronautics and Space Administration (NASA), *Apollo 15 Press Kit, Release no. 71-119K*, July 1971, p. 59, accessed December 28, 2018, https://history.nasa.gov/alsj/a15/A15_PressKit.pdf.

³ Zimbelman. Also, NASA, *Apollo 16 Press Kit, Release no. 72-64K*, April 1972, p. 2, accessed December 28, 2018, https://history.nasa.gov/alsj/a16/A16_PressKit.pdf.

⁴ Zimbelman. Also, NASA, *Apollo 17 Press Kit, Release no. 72-220K*, November 1972, p. 2, accessed December 28, 2018, https://history.nasa.gov/alsj/a17/A17_PressKit.pdf.

The planned **fourth LRV** flight vehicle was not used since missions after Apollo 17 were canceled. Ultimately, the materials designated for this vehicle were assembled by NASA for display purposes as a model. It is now in the collection of the Smithsonian National Air and Space Museum (NASM).⁵

Several **mockups and test units** were built as part of the contract between NASA and Boeing to inform the development and construction of the three flight vehicles. These included:

- An engineering mock-up, now in the collection of Seattle’s Museum of Flight;⁶
- A mass unit to test the effects of the rover on the Lunar Module structure, balance, and handling;
- Two one-sixth gravity units for testing the deployment mechanism;
- A mobility unit to test the mobility system, which was then converted into the one-gravity trainer unit; the one-gravity trainer is now in the collection of the NASM;⁷
- A vibration unit to study the LRV’s durability and handling of launch stresses, now in the collection of the NASM;⁸ and
- A qualification unit to study integration of all LRV subsystems, now in the collection of the NASM.⁹

Physical Characteristics of the LRV¹⁰

NASA required the LRV to be lightweight, easily stowable for transport in the lunar module (LM), and durable enough to withstand a harsh environment. The three flight vehicles were identical to one other with only slight variations in payload weight (figures 25 through 28).

Each LRV flight vehicle weighs about 462 pounds on Earth (or 77 pounds on the Moon; all subsequent figures reflect Earth weights) and can carry a total payload of 1,080 pounds.¹¹ The payload included

⁵ “Lunar Roving Vehicle, #4,” Smithsonian National Air and Space Museum website, accessed December 6, 2018, <https://airandspace.si.edu/collection-objects/lunar-roving-vehicle-4>. At the time of this writing, the Lunar Roving Vehicle, #4 is on loan to the Kennedy Space Center.

⁶ “Boeing Lunar Roving Vehicle Engineering Mock-up,” Museum of Flight website, accessed October 15, 2018, <http://www.museumofflight.org/spacecraft/boeing-lunar-roving-vehicle-engineering-mock>

⁷ “Lunar Roving Vehicle, 1-G Trainer,” Smithsonian National Air and Space Museum website, accessed December 6, 2018, <https://airandspace.si.edu/collection-objects/lunar-roving-vehicle-1-g-trainer>. At the time of this writing, the 1-G Trainer is on loan to Space Center Houston.

⁸ “Lunar Roving Vehicle, Vibration Test Unit,” Smithsonian National Air and Space Museum website, accessed December 6, 2018, <https://airandspace.si.edu/collection-objects/lunar-roving-vehicle-vibration-test-unit> At the time of this writing, the Vibration Test Unit is on loan to the Davidson Saturn V Center at the U.S. Space & Rocket Center in Huntsville, AL.

⁹ “Lunar Roving Vehicle, Qualification Test Unit,” Smithsonian National Air and Space Museum website, accessed December 6, 2018, https://www.si.edu/object/nasm_A19760746000.

¹⁰ The following information is gleaned from NASA’s Apollo 15, 16, and 17 Press Kits and Mission Reports; and “Lunar Rover Operations Handbook,” April 19, 1971, revision July 7, 1971, The Boeing Company, accessed January 31, 2019, <https://www.hq.nasa.gov/alsj/lrvhand.html>; and “Lunar Roving Vehicle [25-page booklet],” undated [ca. 1972], The Boeing Company, Corporate Archives, Bellevue, WA.

two astronauts and their portable life support systems (approx. 800 pounds); communications equipment (150 pounds); scientific equipment and photography gear (150 pounds); and lunar samples (90 pounds). The payload was stored in stowage quadrant three of the LM's descent stage.

The four-wheeled LRV has a box-type chassis that folds for compact storage in the tight, pie-shaped confines of stowage quadrant one of the LM's descent stage. Fully deployed, the vehicle measures 122 inches long, 72 inches wide, and 44.8 inches high, and sits 17 inches above the ground (or 14 inches when loaded). The crewmen sit side-by-side with the front wheels visible to them during normal driving. Two 36-volt batteries power the vehicle for a top speed of about 10 miles per hour, although it averaged about five miles per hour during the three missions. The LRV can climb and descend a 25-degree slope, negotiate 12-inch obstacles and 28-inch crevices, and has 45-degree pitch-and-roll stability. Rover 1 had an assigned range of 40 miles from the LM, while Rovers 2 and 3 had a range of 57 miles, but all three were limited to a radius of six miles, the distance the crew could walk back in the event of a total LRV failure. The vehicle has five major systems: mobility, crew station, navigation, power, and thermal control.

The **mobility system** includes several subsystems: the chassis, wheels, traction drive, suspension, steering, and drive control electronics.

- The aluminum-frame chassis is composed of a forward section that holds both batteries, the navigation system, and the drive control electronics. The center section includes the crew station where both astronauts sit side by side, the control and display console, and the hand controller used by the crew to operate the vehicle. The floor of this section is made of aluminum panels. The aft section is largely reserved for stowing the crew's scientific equipment. The forward and aft sections are designed to fold over the center section and lock in place for transport in the LM.
- Each wheel weighs 12 pounds and measures 32 inches in diameter and nine inches wide. The wheel has a spun aluminum hub, an inner frame or "bump" stop, and an outer layer of a woven mesh zinc-coated piano wire with titanium treads riveted in a chevron pattern.
- The traction drive attached to each wheel has a motor harmonic drive gear unit that allows for continuous operation without gear shifting and also a brake assembly. Each wheel can be uncoupled from the traction drive and brake.
- Two parallel arms connect the chassis with the traction drive of each wheel forming the suspension system. The system was rotated approximately 135 degrees for compact stowage in the LM.
- The front and rear wheels operate on independent steering systems, allowing for a turning radius of 122 inches. The T-shaped hand controller is located between the two crewmen and it maneuvers the vehicle speed and direction. Tilting the controller forward of the neutral position increases forward speed, while pulling it backwards brakes the vehicle. The parking brake is initiated as the controller is pulled backwards three-inches. The brake is released by a "turn left" command. Reversing the vehicle requires tilting the controller backwards and

¹¹ Payload weights differ slightly depending on the mission and publication author. These numbers reflect Apollo 15 and 16 mission data according to the NASA mission press kits, while Apollo 17 had a slightly heavier payload capacity of 1,190.

throwing the reverse inhibit switch on the controller. Moving the controller left or right initiates steering.

The **crew station** consists of the control and display console, seats, footrests, handholds, toeholds, floor panels, and fenders.

- The control and display console gives readings for pitch and roll (attitude indicator), vehicle direction with respect to lunar north (heading indicator), distance traveled (distance indicator), and bearing and distance to the LM (bearing and range indicators). There is a sun shadow device that detects the LRV's heading with respect to the sun. An odometer in the right rear wheel measures the vehicle's speed, which is displayed by the speed indicator. The console includes switches for the four drive motors, two steering motors, and a system reset that allows the bearing, distance, and range displays to be reset. The console monitors vehicle power and temperature and triggers an alarm indicator at the top of the console, which lights up if the battery and temperature readings are of concern.
- The two seats are made of tubular aluminum framing spanned by strips of nylon and are designed to fold flat onto the chassis while stowed and to be unfolded by the astronauts after deployment. Each crewman has a nylon strap seatbelt that fits over their lap and attaches to the outboard handhold.¹²
- There is one armrest located behind the LRV hand controller to support the arm of the crewman who is driving the vehicle.
- There is one footrest for each crewman situated on the center floor section. The footrests, which fold flat against the chassis during transport, are adjusted to fit the crewmen before launch.
- A handhold on each side of the center console assists the crewmen getting in and out of the vehicle. These inboard handholds contain receptacles for camera and communication equipment.
- A toehold on each side of the vehicle is used to assist the crew in getting in and out of the vehicle. The astronauts assemble the toeholds after deployment on the lunar surface by dismantling the tripods that linked the LRV to the LM and inserting a piece of the tripod into either side of the chassis. This piece also doubles as a tool, if needed.
- The crew station floor is beaded aluminum panels.
- Fiberglass fenders extend over each wheel to contain the fine lunar dust while the LRV is in motion. A section of the fenders was retracted during stowage and extended for use after deployment. During the second EVA of the Apollo 16 mission, astronaut John Young bumped into and broke off the right rear fender extension. The issue was not mission-critical, and no repair was made. A similar incident occurred during the first EVA of the Apollo 17 mission when Eugene Cernan inadvertently broke off the right rear fender extension. The break caused the crew to be covered with lunar dust when the vehicle was in motion. At the beginning of the second EVA, the crew fashioned a replacement fender extension using used duct tape, four maps, and clasps. It lasted the remaining duration of the mission but was undone so that the clasps could be used during the return trip in the LM.

¹² The Apollo 15 crew reported that the seatbelts were difficult to fasten and were too short. NASA, *Apollo 15 Mission Report, MSC-05161*, p. 86.

The LRV has a dead reckoning **navigation system**, meaning it uses a pre-determined fixed position with known speed and course to calculate the vehicle's current position. This system includes a directional gyroscope mounted on the forward chassis, a sun shadow device mounted on the control console, odometers on each wheel to record speed and distance, and a small computer or processing unit. The readings are displayed on the control console.

Two 36-volt batteries, distribution wiring, connectors, switches, circuit breakers, and meters make up the LRV's **power system**. The non-rechargeable batteries, each weighing 59 pounds, are housed in magnesium cases located in the forward section. Both batteries were used simultaneously, although each battery could individually power the vehicle, if needed. The batteries were installed in the vehicle and activated on the launch pad five days prior to launch. An auxiliary connector powered the lunar communications relay unit.

A **thermal control system** protects temperature-sensitive instruments throughout the mission with insulation, radiative surfaces, thermal mirrors, thermal straps, and special finishes. A multi-layer thermal blanket protects the batteries and equipment stored in the forward chassis. The batteries have thermal control units where heat is stored and dust-protector covers that are manually opened after vehicle use to expose thermal mirrors (or space radiators) to cool the batteries. The covers automatically close when the temperature stabilizes. Display console instruments are protected by radiation shields, the console external surfaces have a layer of thermal control paint, and handholds, footrests, and floor panels are anodized.

Stowage, Deployment, and Post-Deployment

The LRV folds and was stowed in the LM's descent stage with the aft end pointing up. When folded, the LRV measures 59.5 inches wide, 66 inches long, and 48.48 inches tall (figure 29). Space support equipment holds the folded LRV in place during transit at three points. The astronauts manually deployed the LRV onto the lunar surface following these steps, which take no more than 15 minutes (figure 30):

- While standing on the lunar surface, astronauts sequentially pull two nylon straps, located on either side of the storage bay.
- One crewman ascends the LM ladder and pulls the D-handle to release the folded LRV. A spring-loaded rod pushes the LRV away from the top of the LM, about five inches, until it is stopped by two steel cables. The lower end rotates on two points formed by tripods attached to the chassis.
- Descending the ladder and returning to the two nylon straps, the astronaut pulls the tape on the right side of the storage bay causing a cable storage drum to rotate and releasing two support cables that swivel the LRV outward from the top. Gravity causes the LRV to rotate outward. Two support arms and two telescoping tubes begin to extend to a point just outside the LM. A cable then pulls pins that unlock the forward and aft chassis sections. At 50 degrees of deployment, the aft (top) section, which is under spring pressure, unfolds and locks into position. The wheels release and lock into place.

- As the astronaut continues to pull the nylon strap, the center and aft sections rotate until the rear wheels touch the lunar surface. At this time, the forward section is able to unfold and lock into position.
- The astronaut pulls the second (left) nylon strap, which lowers the forward section to the lunar surface.
- The astronauts then disconnect the deployment hardware from the LRV by pulling a series of release pins, also known as pip pins.¹³ They deploy the fender extensions, set up the control and display console, unfold the seats, and check and prepare other equipment.
- One astronaut boards the LRV, checks the systems, backs the vehicle away from the LM and drives to stowage quadrant three that holds the payload. The vehicle is powered down while both astronauts install the equipment in the LRV.
- A battery-powered lunar communications relay unit (LCRU) is mounted on the forward chassis. It facilitates voice, television, and telemetry communication between the astronauts and Houston's Mission Control Center. It includes a television camera and a high-gain antenna resembling an umbrella that allowed for optimal television transmission. The camera, manufactured by RCA, could be aimed and controlled by the astronauts or remotely controlled by Mission Control Center personnel. A low-gain antenna was for relaying voice and data when the LRV was in motion. The LCRU was designed to operate in different modes – fixed for when the LRV was parked, mobile as the LRV was moving, or hand-carried.

Boeing's major subcontractor, GM Delco Electronics, produced the vehicle's mobility system and built the 1-G trainer. Eagle-Picher Industries, Inc., of Joplin, Missouri, built the batteries, and the United Shoe Machinery Corp., of Wakefield, Massachusetts, built the harmonic drive unit.¹⁴

LRV Integrity

The three LRVs are structures, defined by the landmark ordinance as "any functional construction made usually for purposes other than creating human shelter." Other examples of structures include boats and ships, railroad locomotives and cars, roads, and bridges. To be eligible for landmark status, a structure, or any type of historic resource, must retain integrity sufficient to convey its historic character.

The three flight vehicles remain on the lunar surface and have gone untouched since they were last used during their respective missions in 1971-72. The LRVs and other Apollo mission-related items that remain on the Moon can be seen in high-resolution imagery produced by NASA's Lunar Reconnaissance Orbiter (LRO), which launched in 2009.¹⁵ The LRO imagery confirms that the vehicles

¹³ Apollo Lunar Rover Vehicle exhibit, Museum of Flight, Seattle, WA, October 17, 2018. According to the exhibit, Apollo 15 mission commander David Scott presented two of the LRV pip pins to Oliver C. "Ollie" Boileau, vice-president of Boeing's Aerospace Group, and to Harold J. McClellan, former general manager of Boeing's Space Division, during a post-mission visit to the Boeing Space Center in Kent.

¹⁴ NASA, *Apollo 15 Press Kit, Release no. 71-119K*, p. 96, accessed December 28, 2018, https://history.nasa.gov/alsj/a15/A15_PressKit.pdf.

¹⁵ LRO imagery of Apollo landing sites is archived jointly by NASA, Goddard Space Flight Center, and Arizona State University at: http://www.lroc.asu.edu/featured_sites/#ApolloLandingSites.

are extant and remain in their last-known locations but does not reveal their conditions, although nearly 50 years of exposure to extreme environmental conditions have likely aged the vehicles (figures 4, 11, 17, and 18).

The LRVs clearly retain integrity of location, setting, feeling, and association, as they remain in the lunar environment for which they were designed. The vehicles' design, materials, and workmanship have gone unchanged since their last use. The major unknown is how the extreme environmental conditions have altered the vehicles.

PART III: HISTORICAL / ARCHITECTURAL SIGNIFICANCE

8. Evaluation Criteria

Historical Data (if known)

Designation Criteria:

- A1 Property is associated with events that have made a significant contribution to the broad patterns of national, state, or local history.
- A2 Property is associated with the lives of persons significant in national, state, or local history.
- A3 Property embodies the distinctive characteristics of a type, period, style, or method of design or construction or represents a significant and distinguishable entity whose components lack individual distinction.
- A4 Property has yielded, or is likely to yield, information important in prehistory or history.
- A5 Property is an outstanding work of a designer or builder who has made a substantial contribution to the art.

Criteria Considerations:

Property is

- a cemetery, birthplace, or grave or property owned by a religious institution/used for religious purposes
- moved from its original location
- a reconstructed historic building
- a commemorative property
- less than 40 years old or achieving significance within the last 40 years

Date(s) of Construction: 1969-1971	Other Date(s) of Significance: 1971 and 1972	
Architect: N/A	Builder: Boeing & General Motors	Engineer: NASA & Boeing

Statement of Significance

Describe in detail the chronological history of the property and how it meets the landmark designation criteria. Please provide a summary in the first paragraph (use continuation sheets if necessary). If using a Multiple Property Nomination that is already on record, or another historical context narrative, please reference it by name and source.

See below:

Introduction

To help get man to the moon, we're bringing the moon to Kent. -- The Boeing Co., on the construction of an advanced space-research facility in Kent, Washington¹⁶

The Lunar Rover proved to be the reliable, safe and flexible lunar exploration vehicle we expected it to be. Without it, the major scientific discoveries of Apollo 15, 16, and 17 would not have been possible; and our current understanding of lunar evolution would not have been possible. -- Apollo 17 Lunar Module Pilot Harrison Schmitt¹⁷

Just three lunar rovers were built, and only six men have driven them. Never had so much imagination, research, and public investment gone into the production of a wheeled vehicle. The rover, known officially as the Lunar Roving Vehicle (LRV), made possible the greatest manned explorations of the Moon in 1971-72, and it came from Kent, Washington.

Kent was home to The Boeing Company's new Space Center, private industry's most advanced research and testing facility aimed at space flight and exploration programs, and it positioned the firm as a leading competitor for the National Aeronautics and Space Administration's (NASA) most ambitious projects. It was NASA's selection of Boeing for the design, testing, and assembly of the LRV that took Kent to the Moon, and it all happened in just three years, from 1969 to 1972. Ultimately, the three rovers performed as specified on the Moon, a remarkable testament to those in private industry and in government research agencies who contributed to the program.

The three lunar-based rovers meet City of Kent Landmark **criterion A1**, through their association with events that have made a significant contribution to the broad patterns of local, state or national history, in the following ways:

- The LRV is history's first and only manned lunar surface vehicle, and it made possible the most ambitious scientific missions of NASA's Moon landings. The rover was an instrumental part of the final three missions of the Apollo program in 1971-72. The vehicles enabled astronauts to travel much greater distances on the Moon and to conduct more surface experiments, contributing to our current understanding of lunar evolutionary history.
- The imagination and knowledge that resulted in the LRV was transferred to solving other technological challenges on Earth for years to come. The rover would be of interest to research organizations and government agencies studying mobility, navigation, and robotics.
- Boeing's contract to produce the LRV was largely executed by the company's aerospace division at its Space Center in Kent. Perhaps more than any other Space Center project, the rover captured the interest and imagination of the Kent community, even as the rising unemployment of the Boeing Bust gripped the Puget Sound region.

The rovers also meet City of Kent Landmark **criterion A3**, through their distinct design and construction, in the following ways:

¹⁶ Boeing advertisement, *Kent News-Journal*, Aug. 19, 1964, Diamond Jubilee Edition, p. 5. See figure 31.

¹⁷ Bettye B. Burkhalter and Mitchell R. Sharpe, "Lunar Roving Vehicle: Historical Origins, Development and Deployment," *Journal of The British Interplanetary Society* 48 (1995): 212.

- The LRV represents an ambitious experiment to overcome the many challenges – both known and unknown – of traversing the lunar landscape for which there was no precedent.
- The LRV is both simple and complex. It is simple in form and materials, with four wire-mesh wheels supporting an aluminum chassis with two nylon-strap seats. It is complex in design, with five major inter-connected systems built with redundancies throughout to ensure that a single failure did not end the mission or endanger the crew.

Elaboration

“Space Age City”¹⁸ – Postwar Change Comes to Kent

Its central location in the Green River Valley made Kent a hub of activity for business related to agricultural processing, packing, and shipping in the early- and mid-20th century. Farming had long been a productive way of life for valley residents, including many Japanese Americans.¹⁹ For many, this way of life was upended in 1942 when President Franklin Roosevelt ordered the removal of first- and second-generation Japanese Americans to internment camps during World War II. Their farmland was redistributed to other farmers and most never returned.²⁰ Their absence strained the workforce as the demand for the valley’s agricultural products remained strong during and after the war.

Kent emerged from World War II a changed community. Post-war growth during the Baby Boom years further strained area farmers and dairymen. As land values and taxes increased, planting acreage became too costly for small-scale producers pushing many to sell their land for development. The City annexed large tracts north and south of Kent to bring the areas being developed under local control. Industrial firms began relocating from Seattle and elsewhere in King County to Kent by the mid-1950s, including the Lynch Manufacturing Co., the Heath Manufacturing Co., and the Borden Co. Chemical Division.²¹

But it was the major infrastructure projects in the mid-1950s and early 1960s that would sustain and attract development in and around Kent for years to come. The Valley Freeway (WA-167) was under construction by 1957 and would ultimately connect Kent with Auburn to the south and Renton to the north via a four-lane highway. Construction of Interstates 5 and 405 was also underway during this period, and they would provide important regional connections for Kent. The completion of the Howard Hanson Dam in 1962 brought relief to valley residents, farmers, and business owners alike, who had long been plagued by flooding. These transportation improvements and flood control measures further enticed industry to Kent, most notably The Boeing Company.²²

¹⁸ “Kent...Space Age City,” *Kent News-Journal*, August 19, 1964, Diamond Jubilee Edition, p. 1.

¹⁹ For more on Kent’s early history agricultural past, see Florence K. Lentz, *Kent: Valley of Opportunity*, (Chatsworth, CA: Windsor Publications, Inc., 1990).

²⁰ Lentz, 55-65. And, Alan J. Stein, “Kent – A Thumbnail History,” HistoryLink.org Essay #3587, 2001. Accessed March 1, 2019, <http://www.historylink.org/File/3587>.

²¹ Lucile McDonald, “Farmers Take Steps to Speed Kent’s Industrialization,” *The Seattle Times*, July 8, 1956, magazine section, p. 2.

²² Lentz, 54, 66-67.

Boeing first expanded into the valley in 1944 when it opened a plant in Renton. The post-war success of its commercial, military, and emerging space divisions pushed the company to expand into Kent and Auburn by the 1960s. In early 1964, Boeing announced plans to develop a state-of-the-art Space Center on 320 acres it had recently purchased in Kent. With the announcement, Boeing vice president Lysle Wood said, "Past experience has taught us the value of having our own research and development laboratories, and we are continuing this approach with our space work."²³ The advanced facility would include four laboratories – one to simulate space, another to simulate space flight navigation, a third to research and test microelectronics, and a fourth to test new materials. The space simulation chamber measured approximately 40 feet in diameter by 40 feet high and was the largest such private commercial facility in the United States.²⁴ This new facility would position the company as a leading competitor for civilian and military space contracts for years to come.²⁵

With the announcement, Kent Mayor Alexander Thornton welcomed Boeing to Kent and credited the city council and the planning commission in their foresight to annex large areas around Kent.²⁶ Construction was underway and proceeding quickly during the summer of 1964 as the community celebrated its diamond jubilee with events and retrospectives. The *Kent News-Journal* was full of articles showing the community's evolution, with emphasis on the recent change. In the previous decade, Kent's population had grown from about 3,000 to more than 11,000, and building permit numbers jumped considerably, from 44 building permits totaling \$1,494,485 to 155 permits totaling \$4.14 million in 1963.²⁷ A *Seattle Times* columnist said of the change, "The Boeing move triggered a land-buying stampede...Where cabbages once were king, glittering new industrial plants – many space-oriented – are taking shape."²⁸

Construction of the Boeing Space Center, located along West Valley Highway between South 196th and 212th streets in North Kent, proceeded quickly. The first areas were complete by March 1965. The first group to move into the new facility "were four research engineers, headed by John Van Brokhorst, manager of the space-environment-simulator laboratory, and a secretary, Mrs. Tod [Judy] Williams."²⁹ Another 400 employees would gradually move in through October when construction was completed (figure 32). Kent Chamber of Commerce members were invited to a special tour of the Space Center in advance of the official dedication on October 29. Boeing celebrated its new \$20 million facility in a ceremony with 4,000 guests, including NASA administrator James Webb, who stood in for Vice President Hubert Humphrey, who was scheduled to attend but had to cancel. In his remarks Webb

²³ "New Space Laboratories Planned at Kent Site," *Boeing News*, February 6, 1964, p. 1.

²⁴ Eugene E. Bauer, *Boeing: The First Century*, (Enumclaw, WA: TABA Publishing, Inc., 2000), 196; "Space Labs to be Built This Year," *Kent News-Journal*, February 5, 1964, p. 1.

²⁵ William Clothier, "New Space Center Sharpens the Forward Edge of Research," *Boeing Magazine* 30, No. 10 (October 1965): 3-5.

²⁶ "Mayor Welcomes Boeing to Kent," *The Seattle Times*, February 4, 1964, p. 27.

²⁷ "Kent Growth Is 'Most Dramatic,'" and "Building Permits Reflect Growth," *Kent News-Journal*, August 19, 1964, Diamond Jubilee Edition, p. 2.

²⁸ Robert Twiss, "Now It's Green (back) River Valley," *The Seattle Times*, October 24, 1965, p. 24.

²⁹ "Kent Center Gets First Employes [sic]," *The Seattle Times*, March 11, 1965, p. 20.

said, “it is clear from the outstanding new research facility which has been built here that the Boeing team has thought about the future and is prepared to do something about it.”³⁰

The Space Center was Kent’s first large-scale commercial plant, and “for a time it remained physically isolated in a sea of farmland.”³¹ Boeing had room to expand and other firms with aerospace industry ties could locate nearby. For example, Aero Structures, Inc., a firm that manufactured materials for the aircraft industry, relocated to Kent from Seattle in 1965. In response to the move, industrial park manager Jim Rice said, “I believe the Kent Valley has shown great foresight in its planning and zoning which allows these industries to come in to complement one another.”³² Further enticement was Kent’s strategic location between Tacoma and Seattle, just a few miles east of Sea-Tac International Airport and within a network of regional highways. All of these factors – location, strong public infrastructure, partner firms nearby, and the opportunity to expand facilities – benefited the Space Center as Boeing sought to bring major space contracts to Kent.

NASA and Project Apollo

In October 1957, the Soviet Union successfully launched the Sputnik I satellite into Earth’s orbit, jumpstarting the Cold War-era Space Race with the United States. The following July, the U.S. established the National Aeronautics and Space Administration (NASA) as a civilian government agency dedicated to the peaceful advancement of space science and technology. Among the nine agency objectives outlined in the establishing legislation were “the improvement of the usefulness, performance, speed, safety, and efficiency of aeronautical and space vehicles,” and “the development and operation of vehicles capable of carrying instruments, equipment, supplies, and living organisms through space.”³³ The subsequent development of the lunar rover fit squarely within the agency’s primary and founding objectives.

Still in its infancy, NASA’s manned spaceflight program was challenged by President John F. Kennedy during a special message to Congress on May 25, 1961. His remarks came just weeks after the Soviet Union put the first human, Yuri Gagarin, into Earth’s orbit. In the speech, Kennedy acknowledged the Space Race and challenged the nation to land a man on the Moon and return him safely to earth before the end of the decade. He said, “No single space project in this period will be more impressive to mankind or more important for the long-range exploration of space and not be so difficult or expensive to accomplish...But in a very real sense, it will not be one man going to the moon...it will be an entire nation. For all of us must work to put him there.”³⁴ NASA’s Project Apollo team and its many partners in private industry would respond to this challenge.

³⁰ Robert Twiss, “4,000 at Dedication of Boeing Space Center,” *The Seattle Times*, October 30, 1965, p. 1.

³¹ Lentz, 75.

³² “Aero Structures to Bring 100+ Employees [sic] to Kent,” *Kent News-Journal*, September 15, 1965, p. 1.

³³ Section 102 of the National Aeronautics and Space Act of 1958, As Amended. NASA, 2008, accessed March 1, 2019, <https://history.nasa.gov/spaceact-legishistory.pdf>.

³⁴ Papers of John F. Kennedy. Presidential Papers. President's Office Files. Speech Files. Special message to Congress on urgent national needs, May 25, 1961, accessed February 22, 2019, <https://www.jfklibrary.org/asset-viewer/archives/JFKPOF/034/JFKPOF-034-030>.

Project Apollo was NASA's third manned spaceflight program, succeeding the Mercury and Gemini programs of the late 1950s and early 1960s. Each program and mission built on the technologies and successes of earlier ones. NASA's objective with Project Mercury was to put a person into Earth's orbit and return them safely to Earth. To achieve this, NASA used a one-man, cone-shaped space capsule to launch Alan Shepherd into low orbit in May 1961 and then John Glenn into full orbit in February 1962. The goal of the succeeding Gemini program was to advance space travel techniques and capabilities that would support the lunar missions of the Apollo program. For these missions, NASA used a larger cone-shaped space capsule that carried two astronauts.

The primary objective of the Apollo program was exactly what Kennedy had called for – that astronauts land on the Moon and return safely to Earth by the close of the 1960s. The twelve-year program resulted in thirty-three flights, eleven of which were manned. The final seven missions – Apollo 11 through 17 – involved manned exploration of the lunar surface, and the final three flights carried a lunar roving vehicle. The unmanned flights were missions to qualify the launch and spacecraft vehicles.³⁵

The Apollo program used a new type of spacecraft for its three-crew missions – a three-part vehicle consisting of a combined two-part command and service module (CSM) and a lunar module (LM).³⁶ Once in lunar orbit, the LM and two astronauts separated from the CSM and its one crewman. The CSM remained in lunar orbit while the LM landed on the Moon. The two spacecraft were modified for missions 15, 16, and 17 to accommodate the transport of a lunar roving vehicle.

NASA defined its Apollo missions by type, each with specific tasks, tests, and benchmarks that needed to be completed before moving to the next mission type. The J-class, or J-series, missions were those capable of a longer stay on the Moon and greater surface mobility due to the lunar rover, allowing for more surface experiments. Missions 15, 16, and 17 were classified as J-class and included new types of equipment such as the Metric and Panoramic camera systems, a lunar communications relay unit (LCRU), and a ground-controlled television assembly (GCTA) to aid in improved real-time visual and audio communication with Earth. To accommodate the change in mission type, NASA not only modified the spacecraft vehicles, it also upgraded the spacesuit and portable life support system (PLSS) to function in coordination with the rover.

The Lunar Rover

In July 1969, just five days prior to the launch of Apollo 11 that took the first humans to the Moon, NASA issued a detailed scope of work and request for proposals for development of the Lunar Roving Vehicle. Only weeks earlier, the agency elected to move forward with a rover program, selecting its Marshall Space Flight Center (MSFC) in Huntsville, Alabama, to manage the effort. Saverio F. Morea, a rocket engine specialist, led MSFC's Lunar Roving Vehicle Project Office that reviewed the proposals.

³⁵ National Aeronautics and Space Administration (NASA), *Apollo Program Summary Report* (JSC-09423). Houston, TX: Lyndon B. Johnson Space Center, April 1975, accessed February 22, 2019, <https://www.hq.nasa.gov/alsj/APSR-JSC-09423.pdf>.

³⁶ Hexcel, a firm with Kent ties, produced the landing gear struts of the Apollo 11 lunar landing module. Hexcel is a manufacturer of composite materials for aerospace and industrial markets and opened its Kent plant in 1996.

They closely reviewed four proposals, from Grumman Aerospace, Chrysler Space Division, Bendix Corporation, and The Boeing Company, ultimately awarding Boeing its \$19 million contract on October 29.³⁷ The cost grew to \$38 million by the end of the project.

The vehicle that NASA specified was the result of years of imagination, research, and development. Throughout the early twentieth century science fiction writers provided the first fantastical renderings of lunar rovers. Writers Jerszy Zulawski, Hugo Gernsback, and Homer Eon Flint, for example, imagined vehicles that ranged from a pressurized wheeled vehicle to a tank-like unit with continuous-track treads to a two-legged walking rover.³⁸ The mid-century writings of scientists, such as German-born rocket scientist and aerospace engineer Wernher von Braun, brought science fiction closer to reality. In 1952, the popular *Collier's* magazine published the first of a series of eight issues about outer space "that persuasively made the case for manned space exploration to the Moon and Mars in the foreseeable future."³⁹ Von Braun and his colleagues produced the *Collier's* content that influenced a generation of engineers and physicists, including those who worked on Project Apollo.

Beginning in 1962, NASA sponsored studies to define and design a lunar-surface vehicle. Several leading military and aerospace manufacturing companies produced designs and models of vehicles that ranged significantly in size and weight. Boeing's first prototype, a mobile laboratory known as MOLAB, featured six wheels, a pressurized cabin, and it weighed nearly 8,000 pounds (figure 33). In June 1965, Boeing introduced the vehicle as a

mobile lunar laboratory [that] could be folded into a compact package, cradled atop a lunar excursion module (LEM) landing craft and shipped to the moon aboard a Saturn 5 rocket...Later, another Saturn 5 would streak moonward from Cape Kennedy with a three-man crew in an Apollo cabin – two of them destined to land by LEM, take over MOLAB and begin their exploration. The MOLAB could be controlled from Earth and is designed to carry stereoscopic driving cameras mounted on top of the vehicle.⁴⁰

Within a week of MOLAB's unveiling in June 1965, NASA extended its contracts with both Boeing and Bendix to include a stripped-down version of the MOLAB, called a Mobility Test Unit, and a second smaller rover called a Local Scientific Survey Module (LSSM). Importantly, the LSSM would not have an enclosed cabin and would only weigh between 800 and 1,500 pounds.⁴¹

As these studies proceeded, Boeing was working on NASA's Saturn V rocket and Lunar Orbiter programs while constructing its Space Center in Kent. Within weeks of officially opening, Boeing tested

³⁷ Burkhalter and Sharpe, 204. "Boeing Receives \$19 Million Contract for Moon Vehicles," *Kent News-Journal*, October 31, 1969, p. 1.

³⁸ Burkhalter and Sharpe, 199-200; Saverio F. Morea, "The Lunar Roving Vehicle, A Historical Perspective," *The Second Conference on Lunar Bases and Space Activities of the 21st Century* NASA Conference Publication 3166, vol. 2 (1992): 619, accessed October 15, 2018, https://history.msfc.nasa.gov/lunar/LRV_Historical_Perspective.pdf.

³⁹ David M. Scott and Richard Jurek, *Marketing the Moon: The Selling of the Apollo Lunar Program* (Cambridge, MA: The MIT Press, 2014), 5-7.

⁴⁰ "Compact Car for Moon Tourists Also Their Home on Wheels," *Boeing News*, June 3, 1965, p. 1.

⁴¹ Burkhalter and Sharpe, 201; "Stripped-Down Moon Buggy for Scientific Survey Studied," *Boeing News*, July 15, 1965, p. 1.

its first Lunar Orbiter spacecraft in the vacuum chamber at the Space Center. Boeing and Eastman Kodak were under contract with NASA to build eight orbiters – three test units and five flight models – designed to circle the Moon and take close-up photographs of the lunar surface to help scientists prepare for the Apollo missions. The program launched five unmanned orbiters in 1966 and 1967 resulting in the first photographs from lunar orbit of the Moon and Earth. Additionally, by mid-1967, just six months after the Apollo 1 disaster, Boeing was under contract with NASA to provide technical integration and evaluation (TIE) tasks for the Apollo program, meaning it would support NASA in integrating the Saturn V launch vehicles with the command and service modules, the lunar module, and later the lunar rover.⁴²

Boeing's depth of expertise and experience as well as its advanced facilities favored the company going into NASA's bid process for the lunar rover in the summer of 1969. Informed by its earlier studies of lunar-surface vehicles, NASA specified a light-weight, four-wheeled, battery-powered vehicle that could be folded and stowed in the Apollo Lunar Module. Deployment and navigation were to be simple enough for one astronaut to maneuver while wearing a cumbersome spacesuit. The specifications required that there be no single-point failures in the vehicle that could abort the mission. This ultimately resulted in the use of redundant or double systems throughout the rover, ensuring that, in the event of a failure, another system could take over.⁴³

NASA announced its selection of Boeing for the LRV project on October 29, 1969. Boeing's major subcontractor for the project was General Motors' Delco Electronics Division based in Santa Barbara, California. A tight timeline called for delivery of the first vehicle by April 1971, giving Boeing just eighteen months to design, test, and build the vehicle. A preliminary design was due to NASA just ten weeks into the contract. At Boeing, the rover project was overseen by Oliver C. Boileau and his Kent-based team in the aerospace division. They also had a team in Huntsville managed by engineer Henry Kudish, who was succeeded by Earl Houtz in 1970, and all worked closely with Saverio F. Morea and his group at NASA-MSFC, also based in Huntsville. Of note is the fact no women appear in professional positions on the organizational charts of Boeing's LRV program, where white men dominated the ranks during this era. Women worked primarily in secretarial roles and often were product models in photographs.⁴⁴ LRV program secretaries Sharron Scott and Judy Williams are examples of this trend (figures 34 and 35).

The teams brought to the project considerable knowledge from the previous six years of rover studies. There were two important carry-overs from Boeing's MOLAB to its LRV: the wire wheels and the concept of independent electric motors in each wheel.⁴⁵ Additionally, the ongoing Apollo missions provided the rover team new, real-time information about the lunar surface. In an interview with *The New York Times* shortly after the contract award, Kudish said the Apollo 11 astronauts who landed on

⁴² "Boeing Gets \$20 Million Apollo Integration Job," *Roundup*, June 23, 1967, p. 1. "Apollo Lunar Spacecraft: Historical Snapshot," The Boeing Co. website, accessed January 25, 2019, <https://www.boeing.com/history/products/apollo-lunar-spacecraft.page>.

⁴³ Burkhalter and Sharpe, 204; Robert L. Twiss, "Boeing on the Moon: Firm delighted with Rover Despite Steering Problem," *The Seattle Times*, August 1, 1971, p. F8.

⁴⁴ Scott and Jurek, 41.

⁴⁵ Burkhalter and Sharpe, 201.

the Moon the previous July, “have been of great value in determining some answers to our problems.” Nevertheless, he said, “We had to make many assumptions about the coefficient of friction of the lunar soil, its ability to carry weight and the size of the obstacles that may be encountered, and their distribution.” At this early stage in the project, Kudish said that “the most difficult problems were keeping the weight and volume of the rover down.”⁴⁶

Throughout 1970, Boeing and NASA collaborated on the rover design using various models and mock-ups.⁴⁷ The first iteration of the rover was a static mock-up that enabled the development team to consider human factors related to crew maneuverability, safety, and comfort, as well as how emergencies might inform the vehicle design. An engineering model provided designers a test unit in the laboratory to study vacuum, thermal, and soil conditions. A training model provided the astronauts the true feeling of what it would be like to drive the rover on the lunar surface. It also allowed designers to study the vehicle’s steering and handling of corners. The team built a dynamic test unit to study the LRV and the LM together to understand how they would interact during the boost, translunar injection, and lunar landing phases. The final qualification test unit was built identical to the mission vehicles and was subjected to test conditions exceeding what was expected. This ensured the rover could withstand the physical demands of the missions.⁴⁸

It was during this testing period in 1970 that Boeing, in consultation with NASA, reorganized its lunar rover program staff, resulting in the relocation of the LRV qualification vehicle and flight vehicle assembly from Huntsville to Kent. Earl Houtz replaced Kudish as the Huntsville-based LRV program manager, with Houtz reporting to LRV Program Executive John B. Winch and both reporting to the LRV/Apollo Program Director Harold J. McClellan.⁴⁹ The reasons for the realignments aren’t clear and the program never lost its momentum. In fact, Houtz later received NASA’s Public Service Award for his “outstanding contribution to the success of the Apollo 15 mission.”⁵⁰

Kent: Home of the Boeing Moon Buggy

Six astronauts came to Kent in December 1970 for “a first-hand inspection” of the rover program and to see the final test model, the qualification unit.⁵¹ The first flight vehicle emerged from production at the Space Center in early February, ready for qualification testing.⁵² Six weeks later, on March 10,

⁴⁶ Richard D. Lyons, “Jeep Will Introduce Traffic to Moon,” *The New York Times*, November 9, 1969, p. 76.

⁴⁷ “Rover Program Moves Forward,” *Boeing News*, June 25, 1970, p. 1.

⁴⁸ Henry Kudish, “The Lunar Rover,” *Spaceflight: A Publication of The British Interplanetary Society* 12, no. 7 (July 1970): 270.

⁴⁹ The Boeing Company, Aerospace Group, “Organization Bulletin: Transfer of Lunar Roving Vehicle Qualification Vehicle and Flight Vehicle Assembly,” September 3, 1970. Also, “Organization Bulletin: Lunar Roving Vehicle / Apollo Program Relationships,” November 3, 1970. The Boeing Company, Corporate Archives. Bellevue, WA.

⁵⁰ “Space Agency Honors Boeing Employee [sic],” *The Seattle Times*, October 12, 1971, p. A14.

⁵¹ “Boeing Rolls Out Version of Lunar Unit,” *The Seattle Times*, December 23, 1970, p. 13. Those in attendance were James B. Irwin and David R. Scott, Apollo 15 crew and the first men slated to drive the rover on the Moon; Charles Duke, Apollo 16; Harrison Schmitt, Apollo 17; Robert Parker, support crew for Apollo 15 and 17; and Poulsbo, WA, native Richard Gordon, Apollo 12.

⁵² “For Apollo 15,” *Boeing News*, February 4, 1971, p. 1.

1971, Boeing formally delivered the first flight model of the LRV to NASA in a special ceremony held in the shadow of the space simulation chamber at the Space Center (figure 36). NASA's MSFC director Eberhard Rees accepted the rover on behalf of NASA, telling the Boeing officials and staff in attendance, "You have reason to be proud."⁵³

Indeed, those who worked closest to the rover were quite proud. During the lead-up to the Apollo 15 launch, Boeing electronics craftsman Paul Turcotte told the *Seattle Times*, "Sure, I'm nervous about the Lunar Roving Vehicle...I've dreamed about it operating up there on the moon. In fact, I've lain awake nights thinking about it. There just has to be a feeling of pride when you know something you've worked on is performing on the moon."⁵⁴ His colleague Dave Hendrickson told the *Times*, "There's a lot of all of us in that vehicle...Some of the guys around here put in long hours building that craft...There were several 30-hour days worked. I assembled the thermal blankets, and I know they will do the job."⁵⁵ The Boeing vice president for aerospace, Oliver C. Boileau, echoed their nervous enthusiasm: "I have been to a lot of first flights in 18 years with this company, but never one where so much of the world looked over our shoulder as we pushed the 'go button.' I couldn't help but be a bit nervous, but with the confidence I have in our people who built the Lunar Roving Vehicle I'm certain it will operate on the moon as it should."⁵⁶ Many years later in a 2018 interview with the City of Kent, LRV Program Executive John B. Winch recalled the biggest challenge of the project was the tight timeframe in which to complete the rover, followed by the deployment system: "The rover system was strapped to one of the legs of the lunar landing module. We didn't know exactly what kind of terrain the module would land on, [but] it worked like a charm, no problem whatsoever."⁵⁷

Following the ceremony, the rover was packaged and flown to the Kennedy Space Center in Florida (figure 29).⁵⁸ Boeing finished the second rover in late March and the third by late June, more than three months ahead of schedule. Rovers 2 and 3 were stored at the Kent facility until after the Apollo 15 mission with Rover 1 was complete, in case the vehicles would need modification after the first lunar rover mission in late July 1971. No major modifications were needed and Rovers 2 and 3 shipped closer to their respective launch dates.

As the launch of Apollo 15 neared, excitement in Kent grew as the world's attention turned to the valley-made rover. Fournier Newspapers, which published the *Kent News-Journal*, *Renton Record-Chronicle*, and *Auburn Globe-News*, sent reporters Bill and Wini Carter to cover the launch in Florida. Wini Carter reported that Boeing had set up a press room in one of the area motels and had a model of the rover in the motel lobby that was "the center of attention." They toured the Kennedy Space

⁵³ "NASA receives First Lunar Rover Vehicle," *Boeing News*, March 18, 1971, p. 1.

⁵⁴ Robert L. Twiss, "Boeing on the Moon," *The Seattle Times*, August 1, 1971, p. F8.

⁵⁵ *Ibid.*

⁵⁶ *Ibid.*

⁵⁷ John Winch, (Retired Engineer, LRV Program, Boeing), "Bring the Moon to Downtown Kent," Interview by Michelle Wilmot and Edgar Riebe, City of Kent, May 14, 2018, accessed October 15, 2018, <https://vimeo.com/272473790>.

⁵⁸ NASA, "LRV Flight Model Delivery," Kennedy Space Center News Release, KSC-41-71, March 10, 1971. Accessed November 8, 2018. [p. 13 of PDF] https://www.nasa.gov/centers/kennedy/pdf/744322main_1971.pdf.

Center with other members of the press and attended events and parties in the days leading up to the launch. She wrote that “seeing the launch from Cape Kennedy was an awe-inspiring experience.”⁵⁹

The *Kent-News Journal* featured rover-related highlights with a local angle not found in the major newspapers of the day, and they provide a wonderful window into the excitement and pride for the hometown rover. Mayor Isabell Hogan used the opportunity to promote Kent and mailed a City of Kent decal to Kurt H. Debus, director of the Kennedy Space Center in hopes of getting it affixed to the rover’s fender. The decal did not end up on the rover.⁶⁰ She tried again with Rover 2, also without success. At the unveiling ceremony for Rover 2 (figure 37), Boeing presented Hogan a plaque displaying the special Apollo 15 stamp issued by the U.S. Postal Service and an engraved message denoting Kent as “Hometown of the Lunar Roving Vehicle.”

The enthusiasm touched all ages and interests, from children and parents to elected officials and boosters. The Kent Meeker Days parade, which took place just two days before the Apollo 15 launch and featured ten-year-old Kendall Brookbank, who manned a tin-foil rover replica on a parade float (figure 38). The Kent Jaycees, a junior Chamber of Commerce organization, rode the wave of enthusiasm unveiling a fundraising project selling blue and white buttons with a picture of the lunar rover with text reading *Kent, Washington – Home of the Boeing Moon Buggy* (figure 39). The buttons went on sale just in time for the Apollo 15 astronauts visit to Kent in mid-October 1971.⁶¹ The *News-Journal’s* Wini Carter reported that newspaper executive Don N. Crew had “slipped” souvenir buttons to astronauts Alfred M. Worden, David R. Scott, and James Irwin during their visit.⁶² The paper also pictured R. H. Nelson, general manager of the Saturn/Apollo Skylab Division of Boeing, wearing a button (figure 40). Proceeds from the sale of the buttons went to community betterment projects.⁶³

Local pride in the rover continued through the final Apollo mission in December 1972, but the outward display of enthusiasm was less evident. Perhaps the Boeing Bust, which involved tens of thousands of layoffs in the Puget Sound region between 1969 and 1971, tempered enthusiasm. However, the rounds of layoffs didn’t impact the Space Center as much as other Boeing locations.⁶⁴ In all, Boeing laid off more than 86,000 employees, hitting King County so hard that county executive John Spellman sought federal assistance to ease the burden.⁶⁵ The muted enthusiasm mirrored the declining interest of the nation, which had peaked with the first moonwalk during Apollo 11. As further evidence of this trend, the Apollo 15 moonwalks were the last to be shown live and in their entirety by the three major television networks.⁶⁶

⁵⁹ “Astronauts Blastoff with Moon Buggy: Valley-made Lunar Rover Center of Attention,” *Kent News-Journal*, Jul. 28, 1971, p. 1-2. Canaveral was known as Cape Kennedy from 1963 to 1973.

⁶⁰ *Ibid.* “Moon Riders Return Home,” *Kent News-Journal*, August 11, 1971, p. 1.

⁶¹ “Moon Buggy Buttons Go Over Big, Say Jaycees,” *Kent News-Journal*, October 13, 1971, p. 6.

⁶² Wini Carter, “3 Astronauts Tour Center,” *Kent News-Journal*, October 15, 1971, p. 1.

⁶³ “He’s Stuck on the Moon Buggy,” *Kent News-Journal*, October 15, 1971, p. 4.

⁶⁴ “Kent Space Center Employment ‘Stable,’” *Kent News-Journal*, August 11, 1971, p. 12.

⁶⁵ Eugene E. Bauer, *Boeing: The First Century*, (Enumclaw, WA: TABA Publishing, Inc., 2000), 215. “County to Seek U.S. Cash, Cities to Act on Layoffs,” *Kent News-Journal*, January 16, 1970, p. 1-2.

⁶⁶ Scott and Jurek, 74.

Apollo J-class Missions & Rover Performance

The lunar roving vehicle was the centerpiece technology of the Apollo J-class missions. It enabled a longer stay on the Moon and greater surface mobility, allowing for more surface experiments. NASA produced reports on each Apollo mission and on the entire Apollo program, and these reports inform the following summaries of missions 15, 16, and 17 and the use and performance of the rovers. Upon the completion of the program, NASA reported that “the mission performance of the lunar roving vehicles used on the Apollo 15, 16 and 17 missions was excellent,” and “the vehicles significantly increased the capability to explore and enhanced data return.”⁶⁷ The report presented final performance data collected on each rover during their respective missions (figure 41).

Apollo 15

Launch: July 26, 1971, 9:34 AM EDT, Kennedy Space Center, Florida

Return: August 7, 1971, 4:45 PM EDT, North Pacific Ocean

Mission duration: 12 days, 7 hours, 11 minutes

Lunar landing site: near Hadley Rille, Apennine Mountains (26.13° N, 3.63° E)

Lunar surface duration: 2 days, 18 hours, and 54 minutes.

Launch vehicle: Saturn V (SA-510)

Payload: Endeavor (CM-112); Falcon (LM-10); Lunar Roving Vehicle (LRV)

Crew: Colonel David R. Scott, Commander; seventh person to walk on the Moon

Lt. Colonel James B. Irwin, Lunar Module Pilot; eighth person to walk on the Moon

Major Alfred M. Worden, Command Module Pilot

As Al Worden piloted the CM in lunar orbit, Jim Irwin and Dave Scott guided the LM Falcon to a landing site on the plains of Palus Putredinis adjacent to Hadley Rille near the Apennine Mountains. It was the one of the fastest and hardest lunar landings of the Apollo missions, coming in at 6.8 feet per second. The crew had four primary objectives: to explore the Hadley-Apennine region, set up and activate lunar surface scientific experiments, make engineering evaluations of new Apollo equipment, and conduct lunar orbital experiments and photographic tasks.

The rover allowed the crew to venture a cumulative 17.3 miles, considerably farther from the LM than astronauts of previous missions who traveled on foot. The vehicle averaged 5.7 miles per hour and reached a top speed of 7 miles per hour. Scott and Irwin traversed the lunar surface in the LRV during three extravehicular activities (EVAs) totaling 18 hours, 35 minutes between July 31 and August 2. They collected 170 pounds of lunar samples, set up the Apollo Lunar Surface Scientific Experiments Package (ALSEP) array, obtained a core sample from about 10 feet beneath the lunar surface, and provided descriptions and photographic documentation of the area around the landing site (figures 2 through 8).

Scott and Irwin were the first to pilot the rover on the lunar surface, and they were “very pleased with the vehicle’s performance, particularly, the speed and hill-climbing capacity.”⁶⁸ In a post-flight visit to

⁶⁷ NASA, *Apollo Program Summary Report, JSC-09423*, sec. 4, p. 101.

⁶⁸ NASA, *Apollo 15 Mission Report, MSC-05161*, December 1971, p. 83, accessed February 21, 2019, <https://www.hq.nasa.gov/alsj/a15/ap15mr.pdf>.

the Boeing Space Center, Scott called the rover a “truly remarkable vehicle.”⁶⁹ Of the vehicle’s performance on the lunar surface, they reported that the rover deployment technique, vehicle maneuverability during motion, and the wheel traction as things that worked very well. Conversely, they reported that the rover’s front steering system malfunctioned, but only during the first extravehicular activity (EVA), and that excessive time was needed to secure the rover seatbelts. Additionally, the video signal was lost from the lunar surface camera mounted on the rover.⁷⁰

Once back in lunar orbit, the crew launched the Particles and Fields Subsatellite from the service module. It studied the magnetic field environment of the Moon and mapped the lunar gravity field until it failed in early 1973.

In addition to being the first mission to feature the rover, this mission set several new records for crewed spaceflight. Apollo 15 was the longest Apollo mission; it featured the heaviest payload in a lunar orbit, the most EVAs with the longest total duration, the longest time in lunar orbit, and the first satellite to be placed in lunar orbit by a crewed spacecraft.

The post-mission report concluded that the 1-g trainer had provided the crew “adequate training,” and that they rapidly adapted to the lunar environment.⁷¹ In response to the problems reported during Apollo 15, Rovers 2 and 3 were modified in the following ways: 1) the auxiliary circuit breaker capacity was increased; 2) Velcro was added to the battery covers to provide increased protection against dust, and reflective tape was added to provide more radiative cooling; 3) new under-seat stowage bags with dust covers and modification to stowage bag straps; 4) and stiffened seatbelts with over-center tightening mechanisms were added.⁷²

Despite the many achievements, the legacy of Apollo 15 was marred by controversy. The first problem involved the *Fallen Astronaut*, a small aluminum figurine created by Belgian artist Paul Van Hoeydonck. During the second EVA on August 1, Scott secretly placed the figurine and a plaque bearing the names of fallen American astronauts and Soviet cosmonauts on the lunar surface. Upon public disclosure of the memorial in the year following the mission, it became clear Hoeydonck had a different view of the pre-arranged agreement with the astronauts, which left him feeling slighted. He had not been consulted on the name of the piece, and he was not being credited for the artwork.⁷³ What was largely a dispute between Scott and Hoeydonck was quickly overshadowed by a bigger controversy discovered following the mission. Scott, Irwin, and Worden had secretly carried with them to the Moon unauthorized postmarked postal covers (mailing envelopes) that they sold to a German stamp dealer

⁶⁹ “Astronauts Praise Rover,” *The Seattle Times*, October 14, 1971, p. D1.

⁷⁰ NASA, *Apollo 15 Mission Report, MSC-05161*, p. 101-05

⁷¹ *Ibid.*

⁷² NASA, *Apollo 16 Mission Report, MSC-07230*, August 1972, Appendix A, p. 5-6, accessed February 21, 2019, https://www.hq.nasa.gov/alsj/a16/A16_MissionReport.pdf.

⁷³ Corey S. Powell and Laurie Gwen Shapiro, “The Sculpture on the Moon,” *Slate*, December 16, 2013, accessed January 31, 2019, http://www.slate.com/articles/health_and_science/science/2013/12/sculpture_on_the_moon_paul_van_hoeydonck_s_fallen_astronaut.html.

upon their return.⁷⁴ NASA officials and elected officials weighed in as the controversy received considerable press attention. The three astronauts were reprimanded and never flew again.

Apollo 16

Launch: April 16, 1972, 12:54 PM EST, Kennedy Space Center, Florida

Return: April 27, 1972, 2:45 PM EST, South Pacific Ocean

Mission duration: 11 days, 1 hour, 51 minutes

Lunar landing site: Descartes Highlands (-8.97° N, 15.50° E)

Lunar surface duration: 2 days, 23 hours

Launch vehicle: Saturn V (SA-511)

Payload: Casper (CM-113) and Orion (LM-11); Lunar Roving Vehicle (LRV)

Crew: Captain John W. Young, Commander; tenth person to walk on the Moon

Lt. Colonel Charles M. Duke, Jr., Lunar Module Pilot; ninth person to walk on the Moon

Lt. Commander Thomas K. (Ken) Mattingly, II, Command Module Pilot

In January 1972, NASA announced a 30-day delay in the launch of Apollo 16 due to technical concerns involving an explosive device used to separate the CM from the LM. After modification and additional testing, the subsequent launch on April 16 went without incident. Once in lunar orbit, Thomas Mattingly remained in the CM while John Young and Charles Duke piloted the LM Orion to a landing site on the Descartes Highlands. The crew had three primary objectives: to inspect, survey, and sample materials and surface features near the landing site, emplace and activate surface experiments, and conduct in-flight experiments and photographic tasks from lunar orbit.

Young and Duke traversed the lunar surface in the LRV during three EVAs totaling 20 hours, 14 minutes between April 21 and 23. The vehicle traveled a cumulative 16.59 miles and reached a top speed of 8.7 miles per hour. They collected 209 pounds of lunar samples, set up the Apollo Lunar Surface Scientific Experiments Package (ALSEP) array, obtained core and trench samples, collected measurements with the lunar portable magnetometer, and provided descriptions and both panoramic and 500 mm photography of the region around the landing site. The findings of the mission disproved the pre-mission hypothesis that the geologic formations in this lunar region were volcanic in origin.

During the first EVA, Duke retrieved the largest rock returned by an Apollo mission. Lunar sample 61016, nicknamed Big Muley after the mission's geology team leader William Muehlberger, weighed 26 pounds and was collected from the east rim of Plum Crater. Also, during the first EVA, Young discovered that the LRV's rear steering was not working, but it began working normally later in the EVA. During the second EVA, Young bumped into and broke off the right rear fender extension, an incident that happened in training and during the later Apollo 17 mission. The issue was not mission-critical, and no repair was made. At the end of the third EVA, Duke left a photograph of his family and a U.S. Air Force medallion on the lunar surface (figures 9 through 14). Once back in lunar orbit, the crew launched NASA's second Particles and Fields Subsatellite from the service module, but it failed after 35 days.

⁷⁴ Andrew Chaikin, *A Man on the Moon: The Voyages of the Apollo Astronauts* (New York: Penguin Books, 2007), 496-97.

The post-mission report said, "Performance of the lunar roving vehicle was good." Duke and Young reported that vehicle "control was excellent," and that it "ran in and out of the smaller secondaries with ease."⁷⁵ In addition to the loss of the rear fender extension and the temporary loss of rear steering, they reported elevated battery temperatures and multiple failures of instrumentation hardware.⁷⁶

Following the second rover's performance, the third rover went "essentially unchanged." Only the following minor modifications were reported: 1) fender extension stops were added to each fender to prevent their loss; 2) a signal cable was added to provide navigation information from the rover navigation system; 3) and a decal was added to the aft chassis to aid the crew in locating the proper hole in which to place the pallet stop tether.⁷⁷

Apollo 17

Launch: December 7, 1972, 12:33 AM EST, Kennedy Space Center, Florida

Return: December 19, 1972, 2:24 PM EST, South Pacific Ocean

Mission duration: 12 days, 13 hours, 51 minutes

Lunar landing site: Taurus-Littrow Highlands (20.19° N, 30.77° E)

Lunar surface duration: 3 days, 2 hours

Launch vehicle: Saturn V (SA-512)

Payload: America (CM-114) and Challenger (LM-12); Lunar Roving Vehicle (LRV)

Crew: Captain Eugene A. Cernan, Commander; eleventh person to walk on the Moon

Dr. Harrison H. Schmitt, Lunar Module Pilot; twelfth person to walk on the Moon

Commander Ronald E. Evans, Command Module Pilot

Apollo 17 was the first night launch in NASA's human spaceflight program. LM pilot and geologist Harrison Schmitt was the first scientist-astronaut to land on the Moon. Schmitt and Eugene Cernan guided the LM Challenger to a landing site in the mountainous region of the Taurus-Littrow Highlands. The site was chosen as a location where both older and younger rocks than those found in previous missions might be found. Like the previous J-class missions, objectives for the crew of Apollo 17 were to explore and sample the materials and surface features near the landing site, to set up and activate ALSEP experiments on the lunar surface for long-term relay of data, and to conduct inflight experiments and photography.

Cernan and Schmitt traversed the lunar surface in the rover during three EVAs totaling 22 hours, four minutes between December 11 and 14. They traveled in the rover a cumulative distance of 22.37 miles, which remains the greatest distance humans have traveled on the lunar surface, collecting a record 243 pounds of lunar samples. During the first EVA, Cernan inadvertently broke off the right rear fender extension, causing the crew to be covered with lunar dust when the vehicle was in motion. At

⁷⁵ NASA, *Apollo 16 Mission Report, MSC-07230*, sec. 9, p. 39-40.

⁷⁶ *Ibid.*, sec. 8, p. 1.

⁷⁷ NASA, *Apollo 17 Mission Report, JSC-07904*, March 1973, Appendix A, p. 3, accessed February 21, 2019, https://www.hq.nasa.gov/alsj/a17/A17_MissionReport.pdf.

the beginning of the second EVA, the crew fashioned a replacement fender extension that lasted the remaining duration of the mission (figure 22). It was undone after the third EVA so the materials could be used during the return trip in the LM. The second EVA was the longest, at seven hours, 37 minutes. At the end of the third EVA, the crew unveiled a plaque acknowledging the achievements of the Apollo program (figures 15 through 24).

The post-mission report indicated that Rover 3's deployment was "smooth," its "controllability was good, and no problems were experienced with steering, braking, or obstacle negotiation."⁷⁸ Cernan and Schmitt reported similar problems with the battery temperature and rear fender as those noted by the Apollo 16 crew, as well as minor slippage while the vehicle was in motion. Importantly, the problems never threatened the completion of the mission. The mission report summarized the rover this way: "The rover is an outstanding device which increased the capability of the crew to explore the Taurus-Littrow region and enhanced the lunar surface data return by an order of magnitude and maybe more."⁷⁹

Apollo 17 was the only lunar surface mission to include the Traverse Gravimeter Experiment (TGE), the Surface Electrical Properties (SEP) experiment, and a Biological Cosmic Ray Experiment (BIOCORE). The TGE was carried on the LRV and measured relative gravity at various locations. Using a transmitting device at the LM, the SEP sent electrical signals to an antenna on the LRV to measure electrical properties in the lunar soil. The BIOCORE studied five mice for possible cosmic ray damage. The crew nicknamed the mice Fe, Fi, Fo, Fum, and Phooey, and four of the five survived the mission.⁸⁰

As the crew spent their final moments on the lunar surface, Cernan said:

I'd just like to say that any part of Apollo 17 – or any part of Apollo – that has been a success thus far is probably, for the most part, due to the thousands of people in the aerospace industry who have given a great deal – besides dedication and besides effort and besides professionalism – to make it all a reality. And I would just like to thank them. Because what we've done here and what has been done in the past – as a matter of fact, what has been done for 200 years – you've got to contribute [means "attribute"] to the spirit of the group of people who form the aerospace industry. And I say, "God bless you" and "thank you."⁸¹

Schmitt re-entered the LM first, and as Cernan prepared to ascend the LM ladder, he said:

I'm on the surface; and, as I take man's last step from the surface, back home for some time to come – but we believe not too long into the future – I'd like to just say what I believe history will record. That America's challenge of today has forged man's destiny of tomorrow. And, as we leave the Moon at Taurus-Littrow, we leave as we came and, God willing, as we shall return, with peace and hope for all mankind. Godspeed the crew of Apollo 17.⁸²

⁷⁸ Ibid., sec. 9, p. 1.

⁷⁹ Ibid., sec. 10, p. 20

⁸⁰ Colin Burgess and Chris Dubbs, *Animals in Space: From Research Rockets to the Space Shuttle* (New York: Springer Publishing, 2007), 320. NASA, *Apollo 17 Mission Report, JSC-07904*, Appendix A, p. 25-6.

⁸¹ Eric M. Jones and Ken Glover, eds, *Apollo 17 Lunar Surface Journal*, 1995, accessed November 1, 2018, <https://www.hq.nasa.gov/alsj/a17/a17.html>.

⁸² Ibid.

Cernan remains the last man to have walked on the Moon.

Legacy of the Rover

In his many media interviews about the rover Boeing LRV program manager Henry Kudish always stressed the sophistication of the vehicle. He bristled at those who compared the rover to a golf cart, dune buggy, or a lunar Jeep, noting it had to withstand the vibrations of a launch, the extreme temperatures during flight, the shock of landing, and the harsh lunar landscape.⁸³ Years later in 1988, at a conference on 21st century space activity, his NASA counterpart Saverio F. Morea echoed Kudish in arguing that the rover “truly embodied the sophistication of a spacecraft.” He hoped that the design and construction of the rover would inform contemporary space planners as they revisited the topics of lunar bases and exploring other planets.⁸⁴ It would be another nine years, and a quarter century after Apollo 17, before NASA landed a rover on another celestial body – the *Sojourner*, a remotely operated robot designed for scientific experiments on Mars.

The imagination and knowledge that resulted in the LRV was transferred to solving other technological challenges on Earth. Scientists and researchers in private industry and government research agencies advanced the rover’s pioneering vehicle concepts in their studies of mobility, navigation, and robotics. For example, Mieczyslaw G. Bekker, a leading expert in the design and locomotion of military and off-road vehicles who had consulted with NASA, Boeing, and others during the rover studies of the 1960s, published a seminal work in 1969 advancing the latest vehicle mobility theories in *Introduction to Terrain-Vehicle Systems*.⁸⁵ The U.S. Bureau of Mines was particularly interested in the rover’s robotics and mobility technologies for adaptation in mines. The rover technology informed 1970s-era researchers studying mobility aids for disabled persons. In particular, the joystick hand-controller concept proved useful for both wheelchairs and automobiles.⁸⁶

The experiences and discoveries of the Apollo missions continue to inform all these years later. On March 11, 2019, NASA announced the selection of nine teams to study pieces of the Moon that have been stored and gone untouched for nearly 50 years. The samples, collected during the Apollo 15, 16, and 17 missions from 1971 and 1972, were stored for study at a later date when technology would be more advanced.⁸⁷

Today, the Apollo missions are back in the news as half-century anniversary dates come and go and as space exploration receives renewed attention.⁸⁸ Although Boeing’s presence in Kent is considerably

⁸³ Kudish, 270. Roger Koch, “Sophisticated Lunar Rover Vehicle More than A ‘Tough Jeep,’” *Boeing News*, December 4, 1969, p. 4. “Lunar Rover Features Electric Drive Wheels, Swivel Seats,” *Boeing News*, December 11, 1969, p. 4.

⁸⁴ Morea, 631.

⁸⁵ Burkhalter and Sharpe, 212.

⁸⁶ E. Peizer, “Technical Aids,” *Prosthetics and Orthotics International* 2 (1978): 107.

⁸⁷ NASA, “NASA Selects Teams to Study Untouched Moon Samples,” March 11, 2019, accessed March 15, 2019, <https://www.nasa.gov/feature/nasa-selects-teams-to-study-untouched-moon-samples>.

⁸⁸ NASA, “NASA Unveils Sustainable Campaign to Return to the Moon, on to Mars,” September 18, 2018, accessed March 15, 2019, <https://www.nasa.gov/feature/nasa-unveils-sustainable-campaign-to-return-to-moon-on-to-mars>.

less than it was during the Space Race, other aerospace firms such as Blue Origin have filled the void.⁸⁹ Kent remains poised to again play a central role in a return to the Moon.

⁸⁹ Marc Stiles, "Boeing Selling 72 Acres in Kent to IDS for Warehouses," *Puget Sound Business Journal*, December 11, 2012, accessed March 15, 2019, <https://www.bizjournals.com/seattle/news/2012/12/11/california-company-plans-large.html>.

INDEX OF IMAGES

- Figure 1 Map of the Moon, with Apollo J-mission landing sites highlighted
- Figure 2 Apollo 15 Lunar Site, in the Hadley-Apennine region, 1971
- Figure 3 Apollo 15 Lunar Site, vertical view of the Hadley-Apennine region, 1971
- Figure 4 Apollo 15 Lunar Site, close-in view showing visible remnants of the mission, 2011
- Figure 5 Apollo 15 astronaut David R. Scott, seated in the LRV, Jul. 31, 1971
- Figure 6 Apollo 15 astronaut James B. Irwin, near the LRV, Jul. 31, 1971
- Figure 7 Apollo 15 astronaut James B. Irwin salutes flag, Aug. 1, 1971
- Figure 8 Apollo 15 traverse map noting location of LM and paths of LRV during three EVAs
- Figure 9 Apollo 16 Lunar Site, in the Descartes Highlands region, 1972
- Figure 10 Apollo 16 Lunar Site, vertical view of the Descartes Highlands region, 1972
- Figure 11 Apollo 16 Lunar Site, close-in view showing visible remnants of the mission, 2011
- Figure 12 Apollo 16 astronaut John W. Young, with LRV behind him, Apr. 23, 1972
- Figure 13 Apollo 16 astronaut John W. Young drives the LRV, Apr. 21, 1972
- Figure 14 Apollo 16 traverse map noting location of LM and paths of LRV during three EVAs
- Figure 15 Apollo 17 Lunar Site, in the Taurus-Littrow Highlands and valley area, 1972
- Figure 16 Apollo 17 Lunar Site, vertical view of the Taurus-Littrow Highlands and valley area, 1972
- Figure 17 Apollo 17 Lunar Site, close-in view showing visible remnants of the mission, 2011
- Figure 18 Apollo 17 Lunar Site, extreme close-in view of LRV in final parking spot, 2011
- Figure 19 Apollo 17 astronaut Eugene A. Cernan driving the LRV, Dec. 11, 1972
- Figure 20 Apollo 17 Lunar Site, LRV sits parked, Dec. 1972
- Figure 21 Apollo 17 astronaut Eugene A. Cernan next to the LRV, Dec. 13, 1972
- Figure 22 Apollo 17 close-up of LRV with makeshift repair to fender, Dec. 12, 1972
- Figure 23 Apollo 17 Lunar Site, LRV shown in final parking spot, Dec. 13, 1972
- Figure 24 Apollo 17 traverse map noting location of LM and paths of LRV during three EVAs
- Figure 25 "Lunar Roving Vehicle – Spacecraft on Wheels [2-page flyer]." Boeing, ca. 1971
- Figure 26 "LRV Detail Drawing." *Boeing News*, July 8, 1971, p. 3
- Figure 27 "LRV Components and Dimensions." NASA Press Kit for Apollo 15
- Figure 28 LRV Line Drawing: LRV Stowed Payload Installation, NASA-MSFC News Release, 1971
- Figure 29 LRV shown folded for stowage on spacecraft, at Boeing Space Center, Mar. 1971
- Figure 30 Illustration of LRV Deployment Sequence
- Figure 31 Boeing advertisement about Kent Space Center, *Kent News-Journal*, Aug. 19, 1964
- Figure 32 Boeing's new Space Center, *Boeing News*, Aug. 5, 1965
- Figure 33 Illustrations of Boeing's MOLAB, *Boeing News*, Jun. 3, 1965.
- Figure 34 Boeing LRV Program secretary Sharron Scott, sitting in an LRV, 1971
- Figure 35 Boeing LRV Program secretary Judy William, 1965
- Figure 36 News clipping and photo of the first LRV, Mar. 10, 1971
- Figure 37 Mayor Isabel Hogan examines Rover 2, *Kent News-Journal*, Aug. 18, 1971
- Figure 38 Kendall Brookbank, age 10, with a tin-foil replica rover, *Kent News-Journal*, Jul. 28, 1971
- Figure 39 Kent Jaycees "moon buggy" button
- Figure 40 Boeing's R. H. Nelson, wearing a "moon buggy" button
- Figure 41 Table showing LRV performance during Apollo 15, 16, and 17 missions

Figure 1: This map of the Moon shows the Apollo J-mission landing sites in green. The arrows point to missions 15 (left), 16 (center), and 17 (right). Digital image archived by NASA at https://nssdc.gsfc.nasa.gov/planetary/lunar/moon_landing_map.jpg

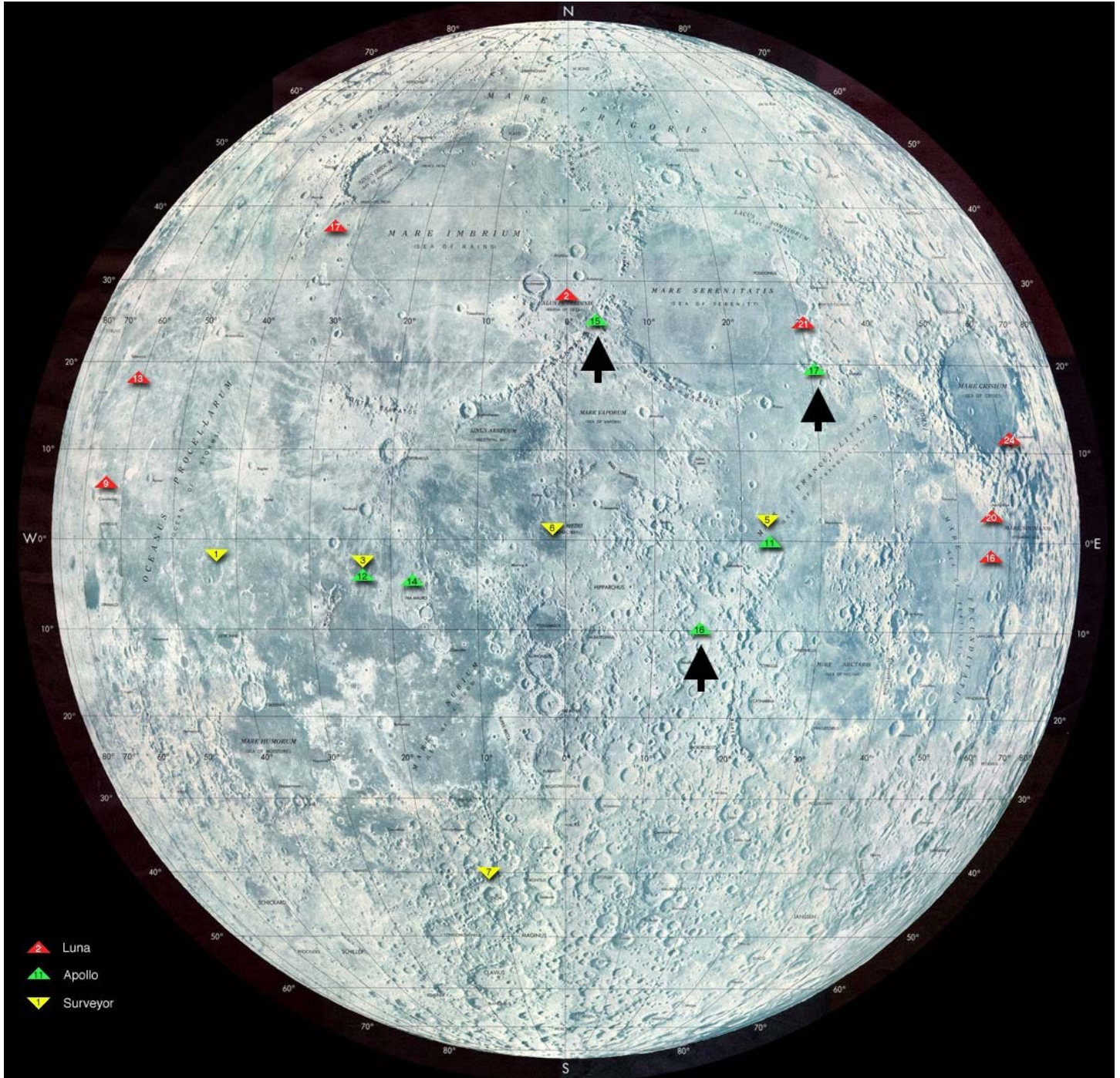

Figure 2: Apollo 15 Lunar Site. The arrow points to the Hadley-Apennine landing site, adjacent to the Apennine mountain range. *NASA photograph AS15-M-1537, taken Aug. 1, 1971.* Digital image archived by NASA/JSC/Arizona State University at http://wms.lroc.asu.edu/apollo/view?image_id=AS15-M-1537

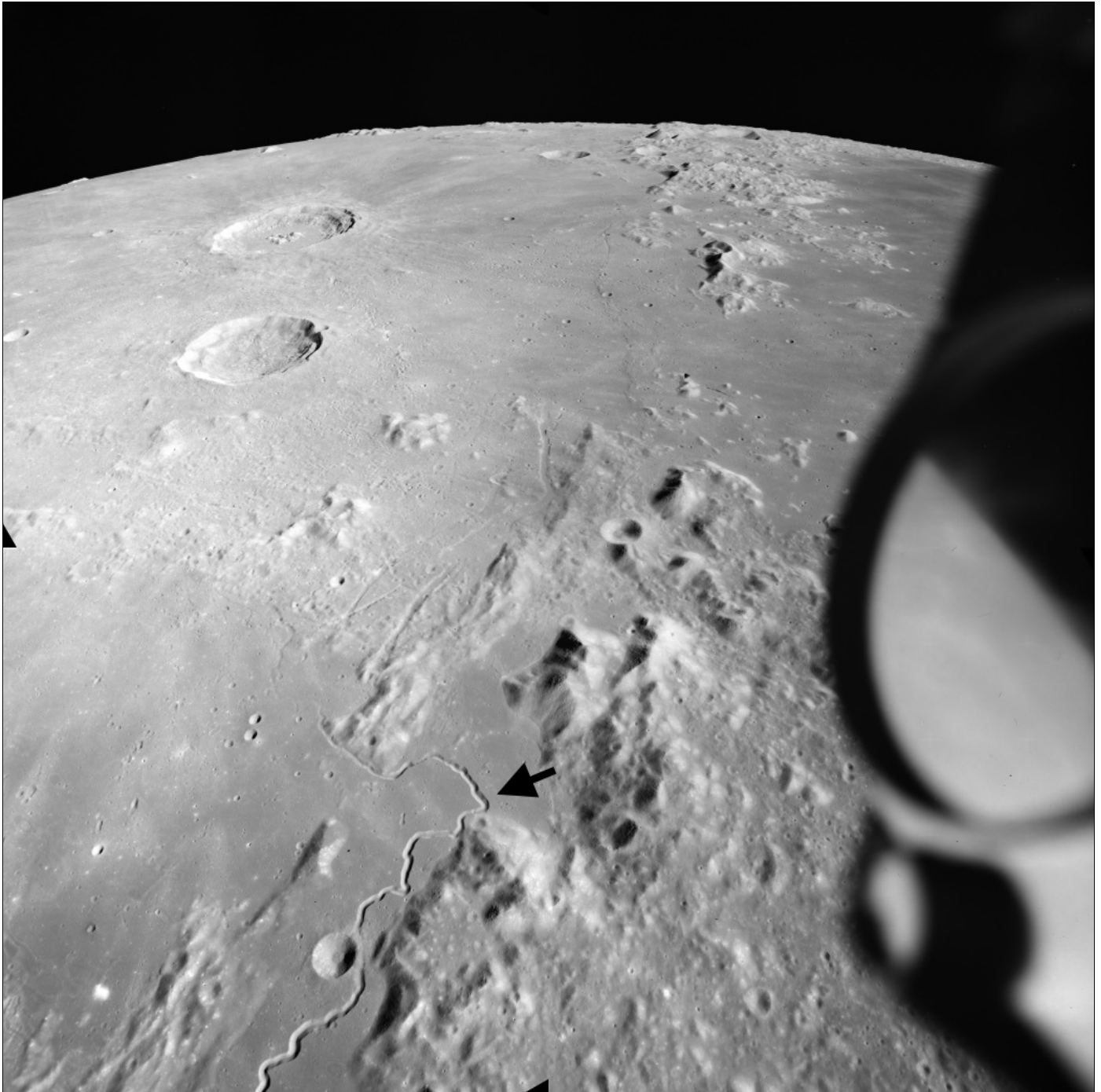

Figure 3: Apollo 15 Lunar Site – Vertical View. The arrow points to the Hadley-Apennine landing site, adjacent to the Apennine mountain range. *NASA photograph AS15-M-1135, taken Aug. 1, 1971.* Digital image archived by NASA/JSC/Arizona State University at: http://wms.lroc.asu.edu/apollo/view?image_id=AS15-M-1135



Figure 4: Apollo 15 Lunar Site – 2011. The white arrows point to the visible remnants of the mission, and the small black arrows point to LRV tracks. This image was taken from an altitude of 25 km by the Lunar Reconnaissance Orbiter (LRO). Image Credit: NASA/GSFC/Arizona State University, M175252641L. This and other LRO imagery at: http://www.lroc.asu.edu/featured_sites/#ApolloLandingSites

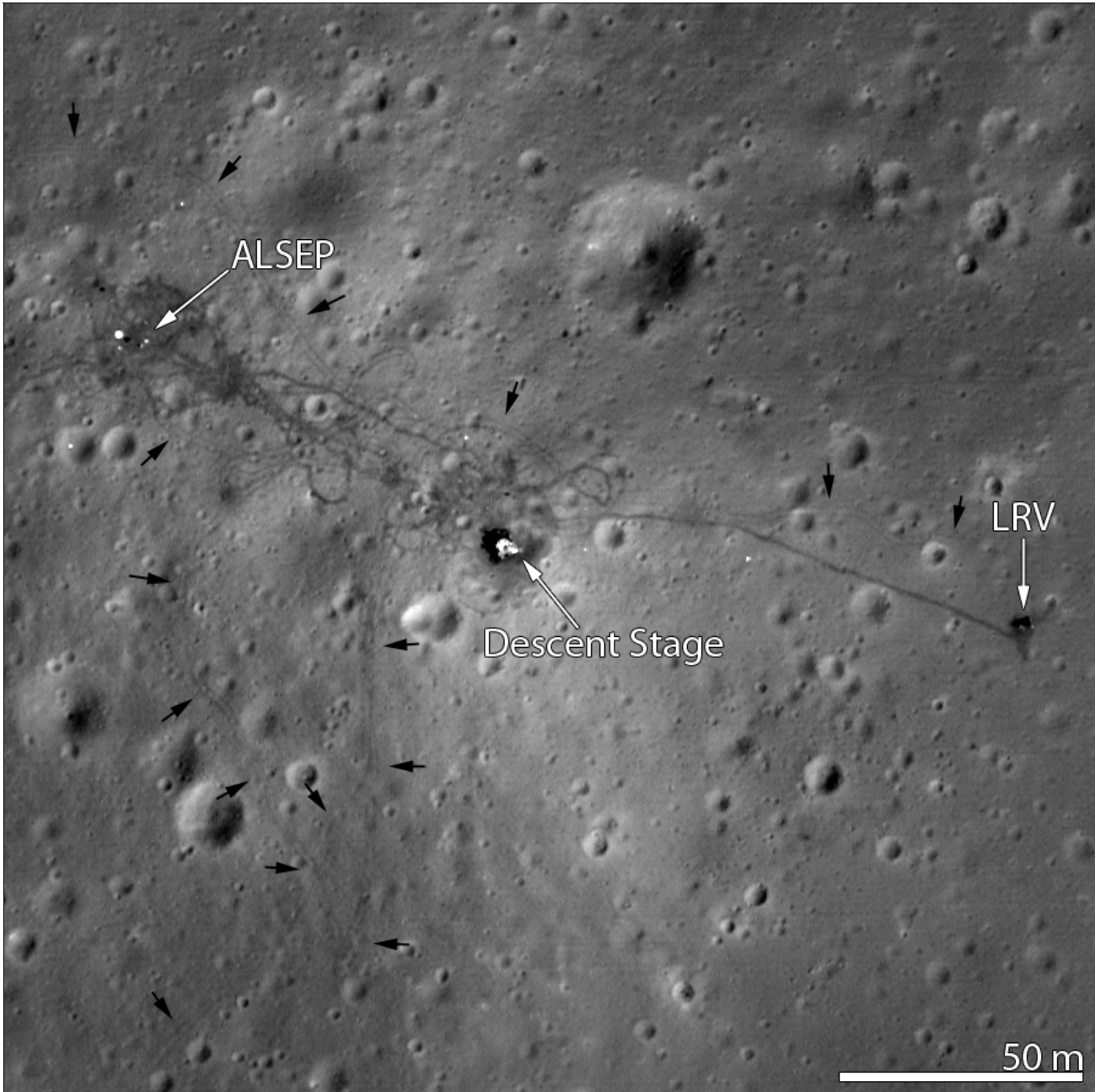

Figure 5: Apollo 15 astronaut David R. Scott is seated in the LRV during the first EVA at the Hadley-Apennine landing site. Astronaut James B. Irwin took the photograph. *NASA photograph AS15-85-11471, taken Jul. 31, 1971.* Digital image archived by NASA at: <https://spaceflight.nasa.gov/gallery/images/apollo/apollo15/html/as15-85-11471.html>

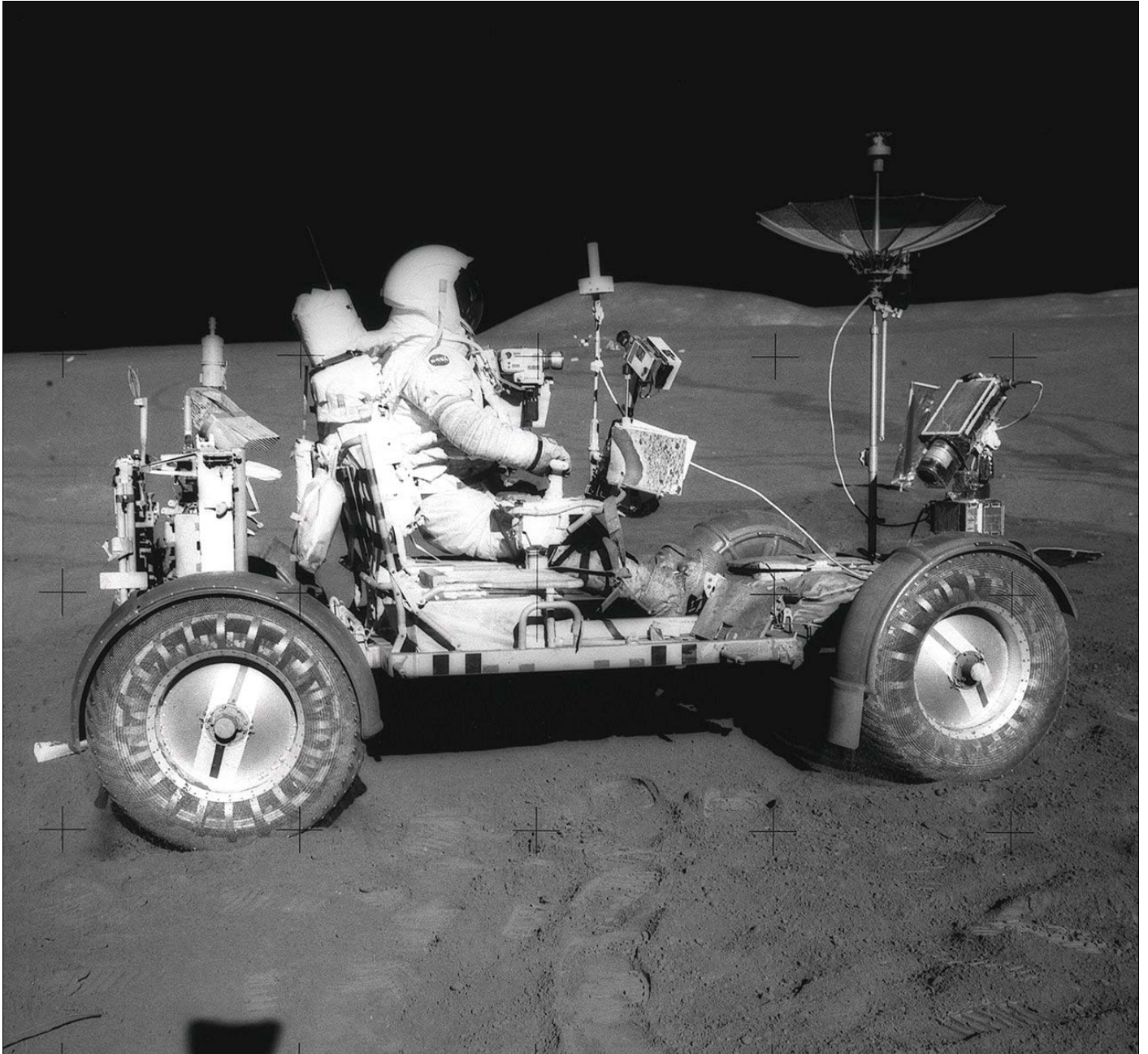

Figure 6: Apollo 15 astronaut James B. Irwin works near the LRV during the first EVA at the Hadley-Apennine landing site. Mount Hadley is in the background. Astronaut David R. Scott took the photograph. *NASA photograph AS15-86-11603, taken Jul. 31, 1971.* Digital image archived by NASA at: <https://spaceflight.nasa.gov/gallery/images/apollo/apollo15/html/as15-86-11603.html>



Figure 7: Apollo 15 astronaut James B. Irwin gives a military salute while standing beside the deployed United States flag during the mission's second EVA at the Hadley-Apennine landing site. The Falcon Lunar Module is in the center, and the LRV is to the right. Hadley Delta rises in the background.

Astronaut David R. Scott took the photograph. *NASA photograph AS15-88-11866, taken Aug. 1, 1971.*

Digital image archived by NASA at:

<https://spaceflight.nasa.gov/gallery/images/apollo/apollo15/html/as15-88-11866.html>

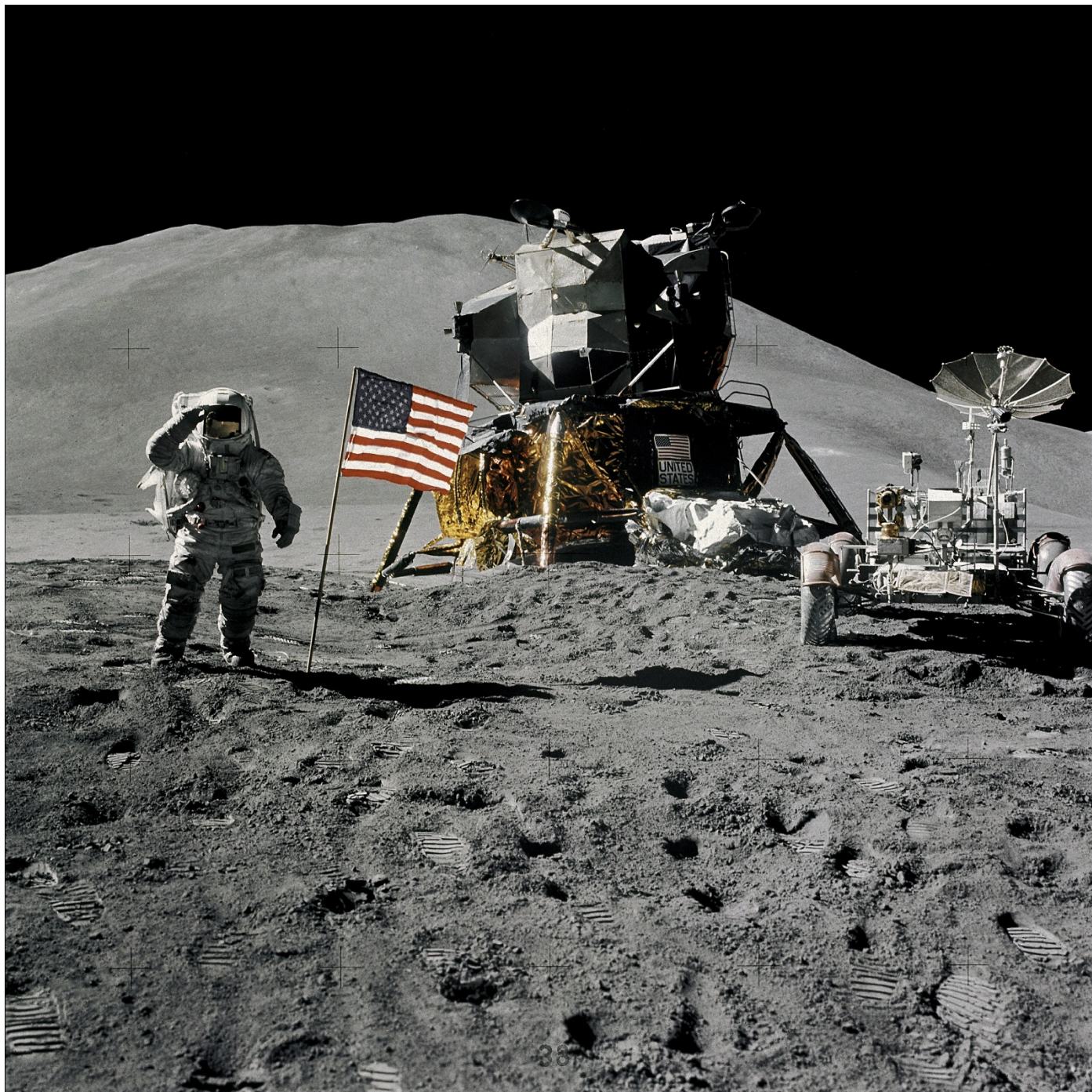

Figure 8: Apollo 15 Traverse Map. The X marks the location of the Falcon Lunar Module. The dark lines indicate the paths taken by the astronauts in the LRV during the three EVAs. The numbers reference scientific sampling stations. *Source:* James R. Zimelman, Lunar and Planetary Institute website: <https://www.lpi.usra.edu/publications/slidesets/apollolanding/>

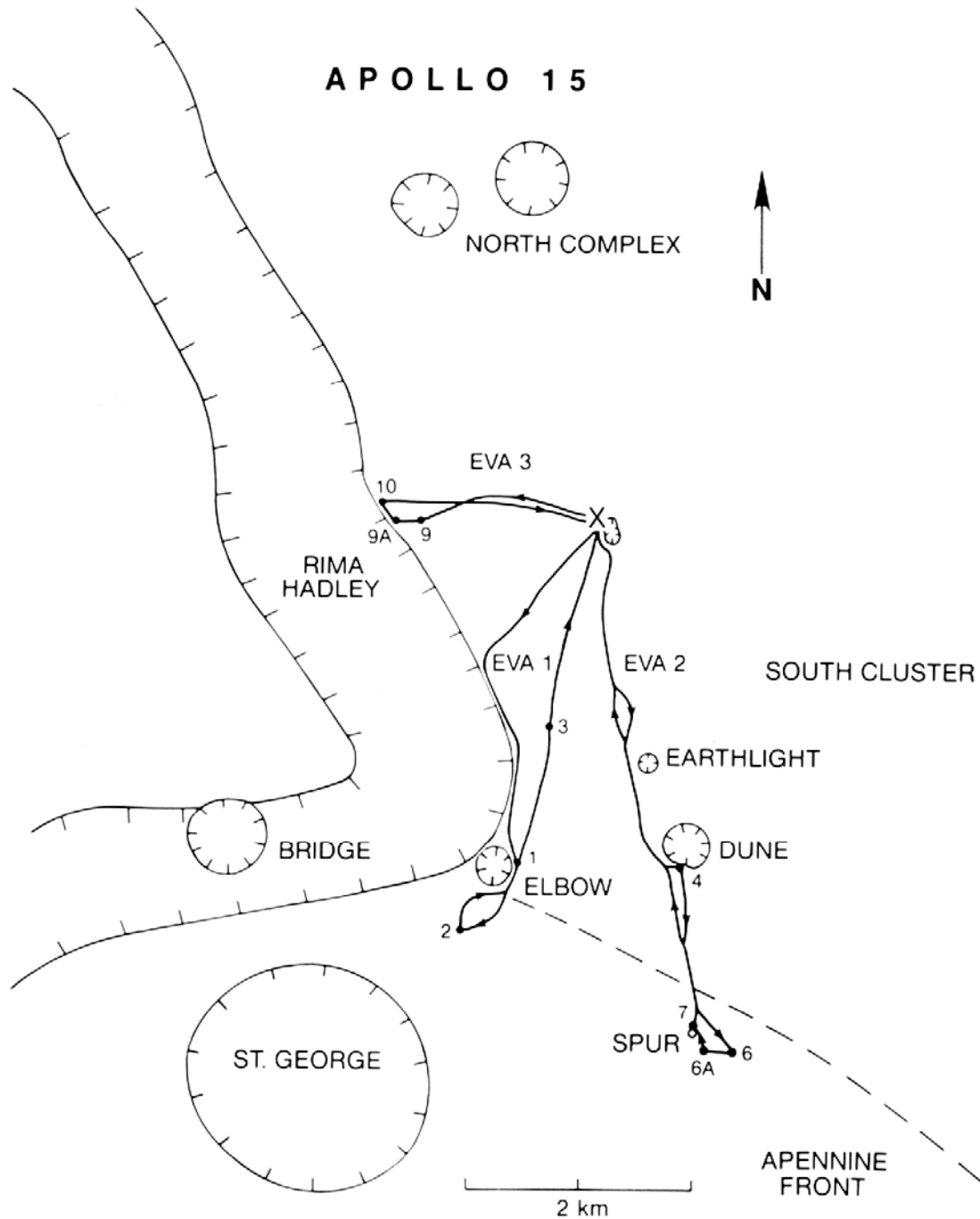

Figure 9: Apollo 16 Lunar Site. The arrow points to the landing site in the Descartes Highlands. *NASA photograph AS16-M-2464, taken Apr. 23, 1972.* Digital image archived by NASA/JSC/Arizona State University at http://wms.lroc.asu.edu/apollo/view?image_name=AS16-M-2464

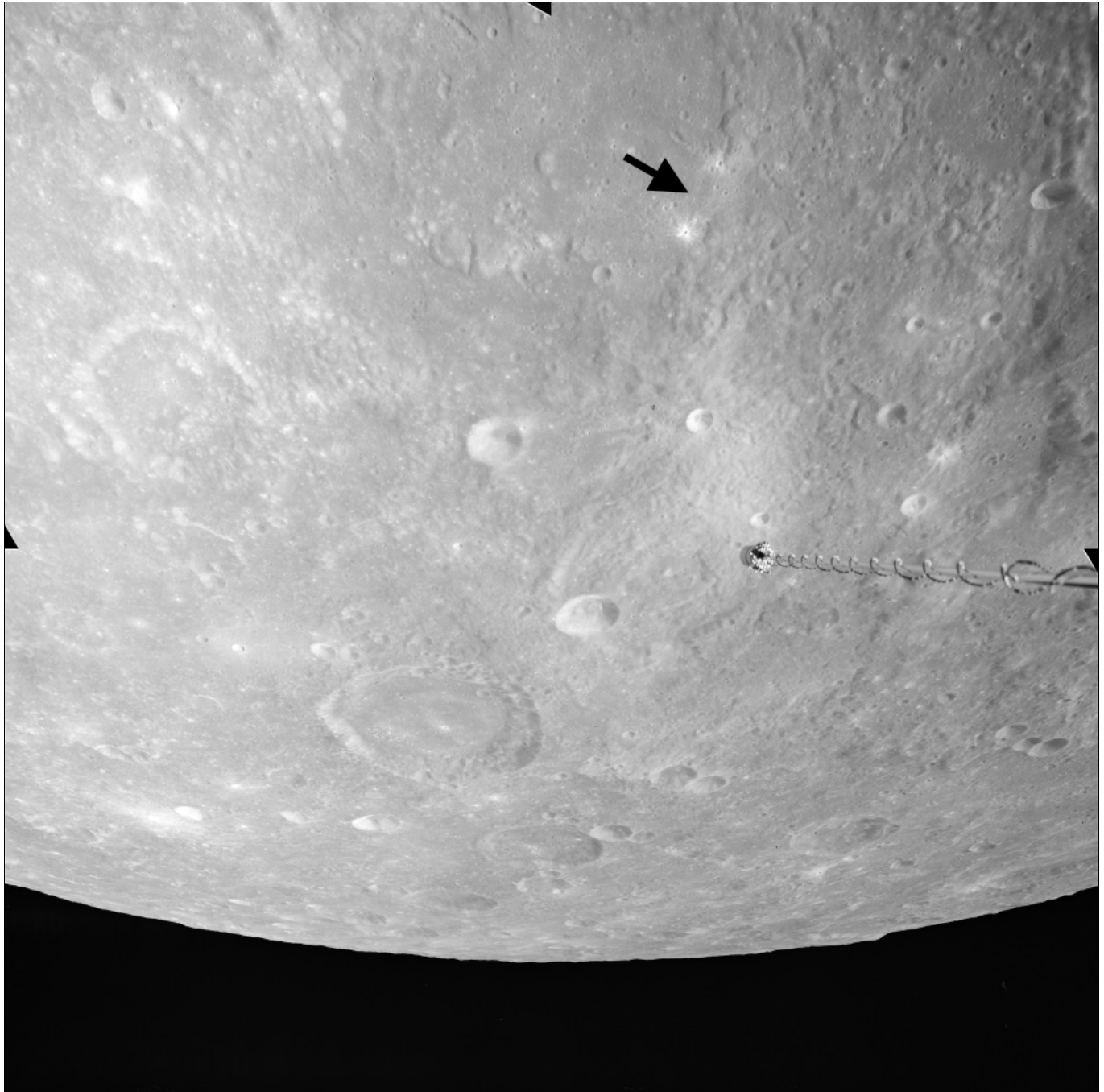

Figure 10: Apollo 16 Lunar Site – Vertical View. The arrow points to the landing site in the Descartes Highlands. *NASA photograph AS16-M-0161, taken Apr. 21, 1972. Digital image archived by NASA/JSC/Arizona State University at: http://wms.lroc.asu.edu/apollo/view?image_id=AS16-M-0161*

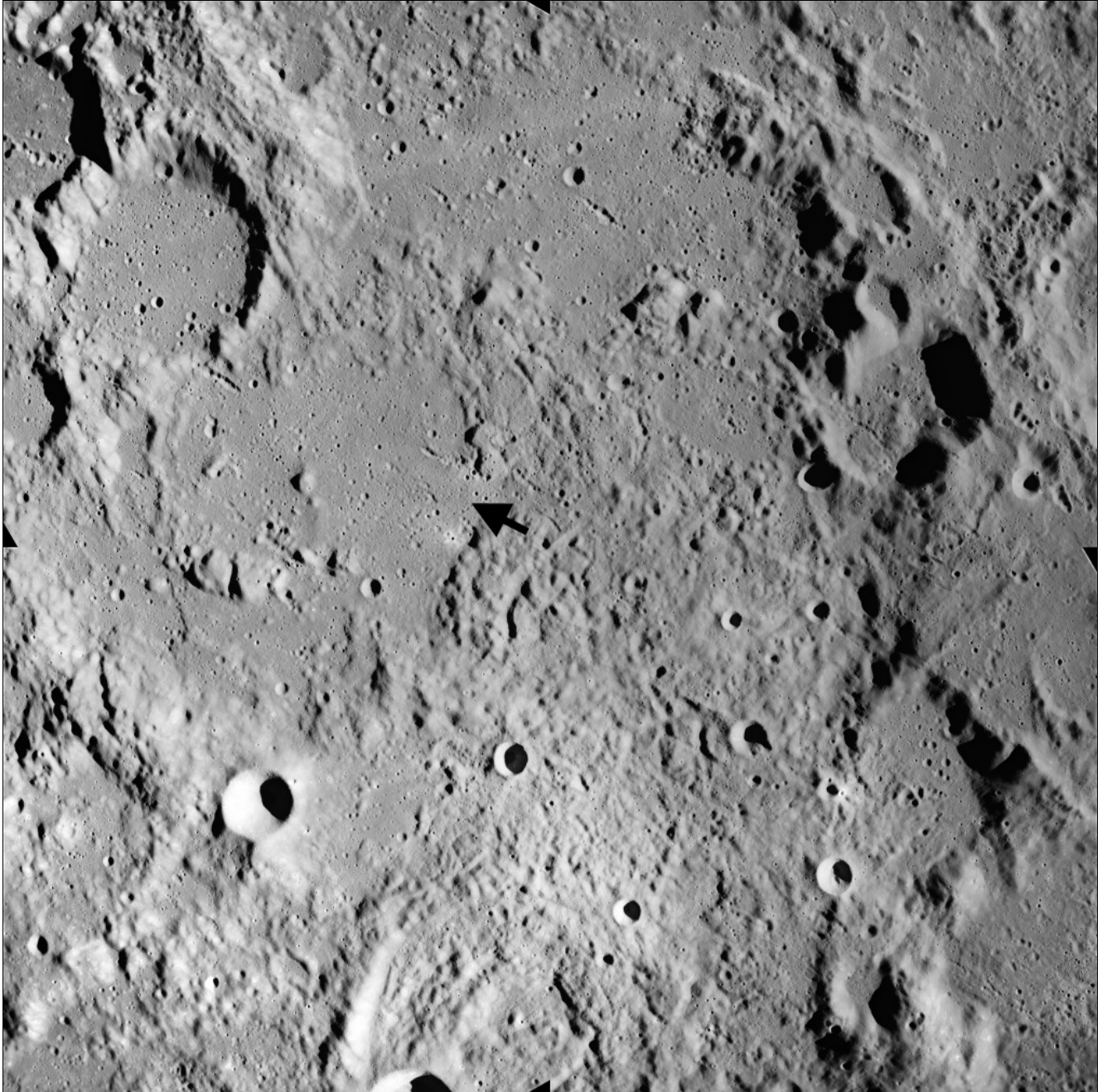

Figure 11: Apollo 16 Lunar Site – 2011. The arrows point to the visible remnants of the mission and the LRV tracks. The Lunar Portable Magnetometer (LPM) is closest to the LRV. This image was taken from an altitude of 23 km by the Lunar Reconnaissance Orbiter (LRO). Image Credit: NASA/GSFC/Arizona State University, M175179080. This and other LRO imagery at: http://www.lroc.asu.edu/featured_sites/#ApolloLandingSites

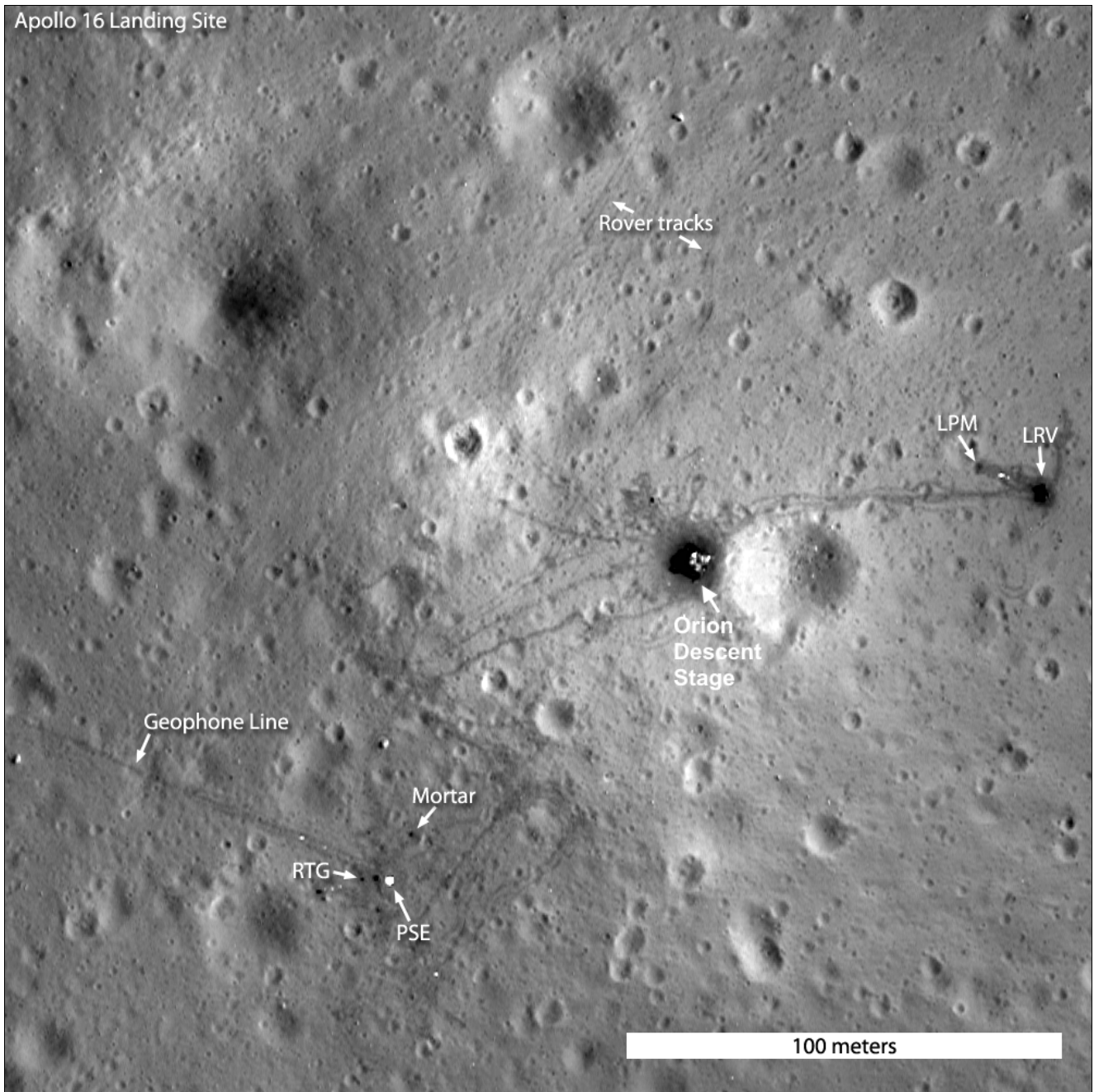

Figure 12: Apollo 16 astronaut John W. Young collects samples at the North Ray Crater geological site on the mission's third and final EVA. The LRV is parked behind him. *NASA photograph AS16-117-18825, taken Apr. 23, 1972.* Digital image archived by NASA at: <https://spaceflight.nasa.gov/gallery/images/apollo/apollo16/html/as16-117-18825.html>



Figure 13: Apollo 16 astronaut John W. Young drives the LRV near the Descartes Highlands landing site on the mission's first EVA. This view is a frame from motion picture film camera held by astronaut Charles M. Duke, Jr. *NASA photograph S72-37002, taken Apr. 21, 1972.* Digital image archived by NASA at: <https://spaceflight.nasa.gov/gallery/images/apollo/apollo16/html/s72-37002.html>

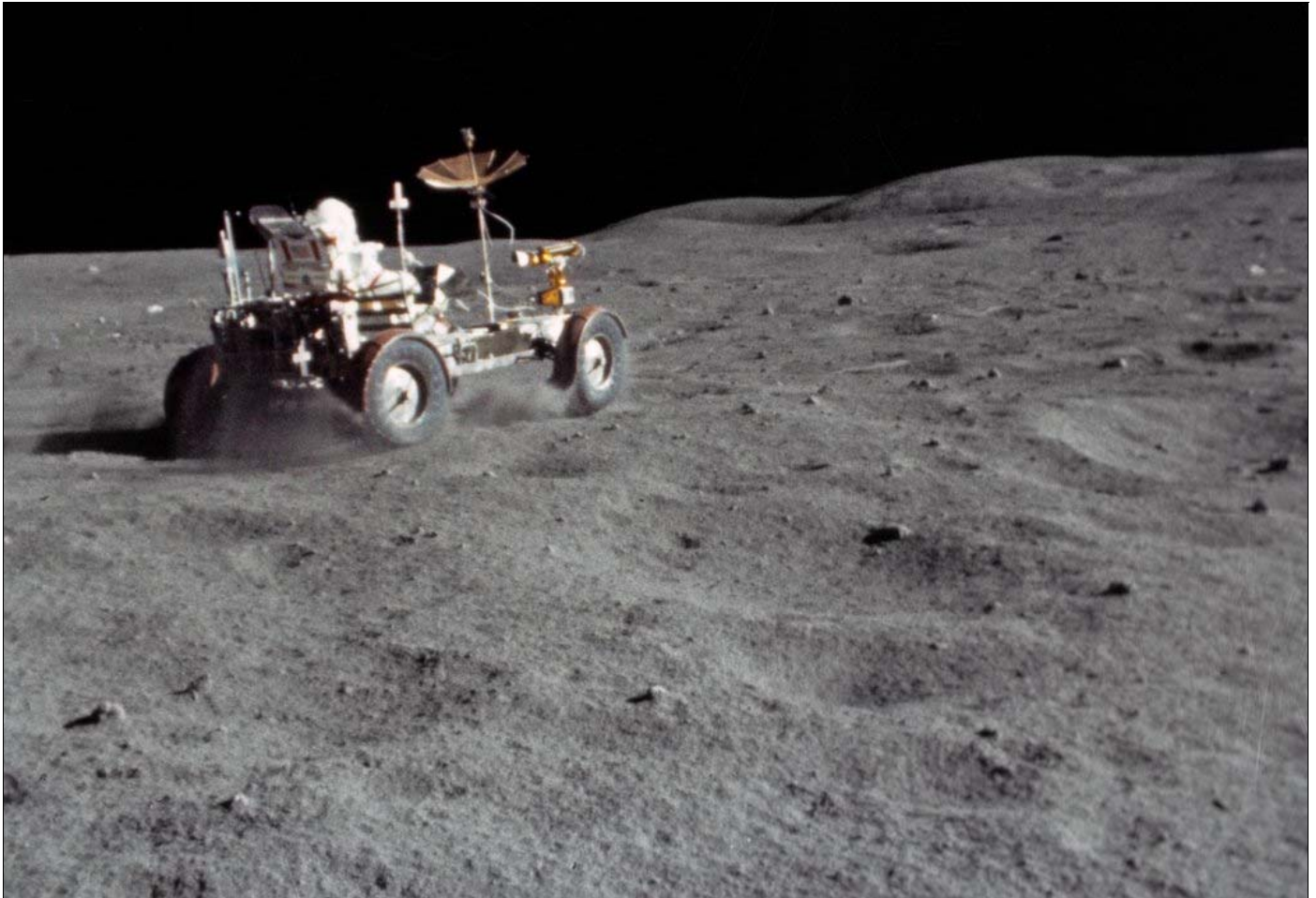

Figure 14: Apollo 16 Traverse Map. The X marks the location of the Orion Lunar Module. The dark lines indicate the paths taken by the astronauts in the LRV during the three EVAs. The numbers reference scientific sampling stations. Source: James R. Zimelman, Lunar and Planetary Institute website: <https://www.lpi.usra.edu/publications/slidesets/apollolanding/>

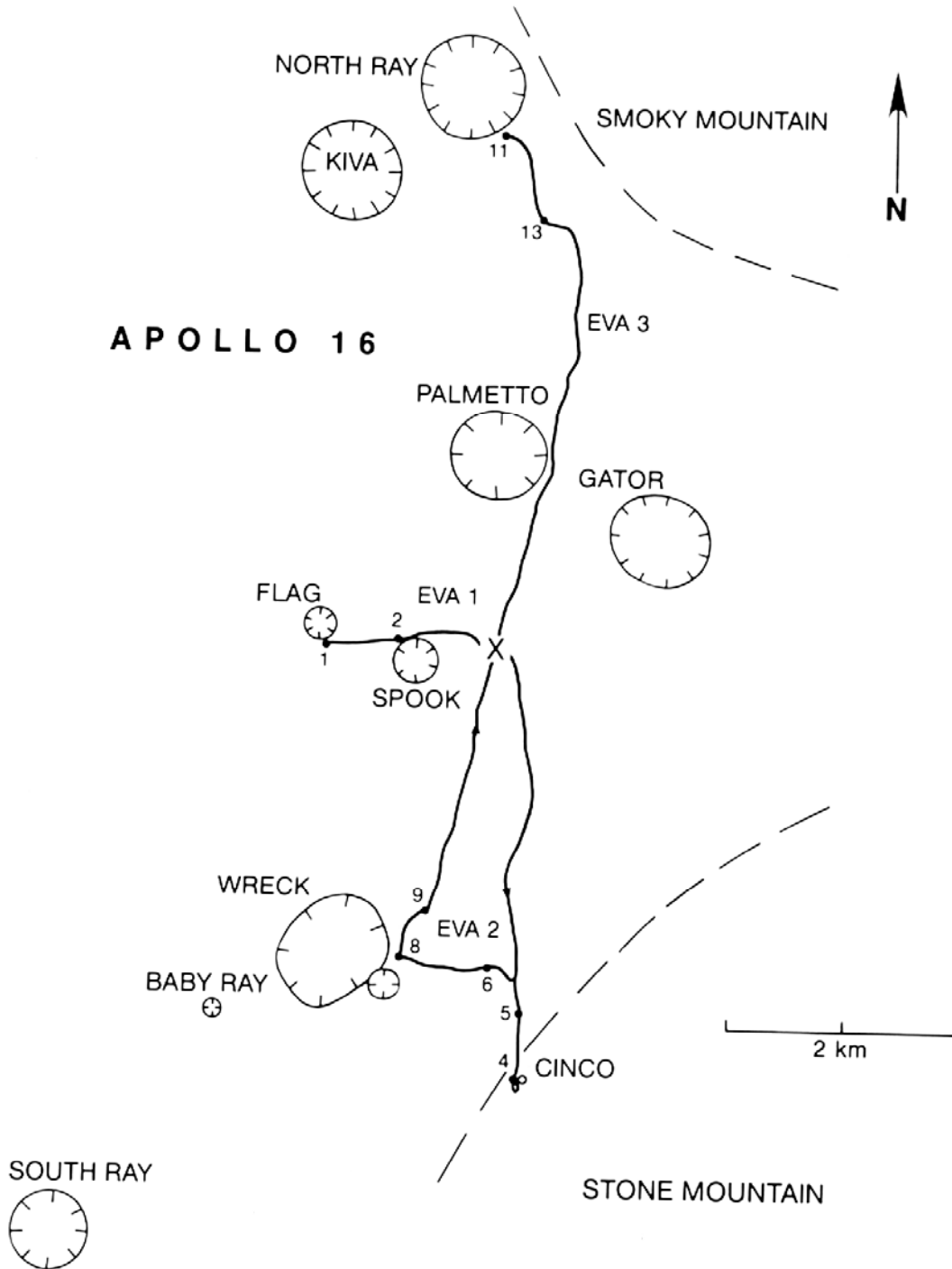

Figure 15: Apollo 17 Lunar Site. The arrow points to the landing site in the Taurus-Littrow Highlands and valley area. NASA photograph AS17-M-0939, taken Dec. 12, 1972. Digital image archived by NASA/JSC/Arizona State University at: http://wms.lroc.asu.edu/apollo/view?image_name=AS17-M-0939

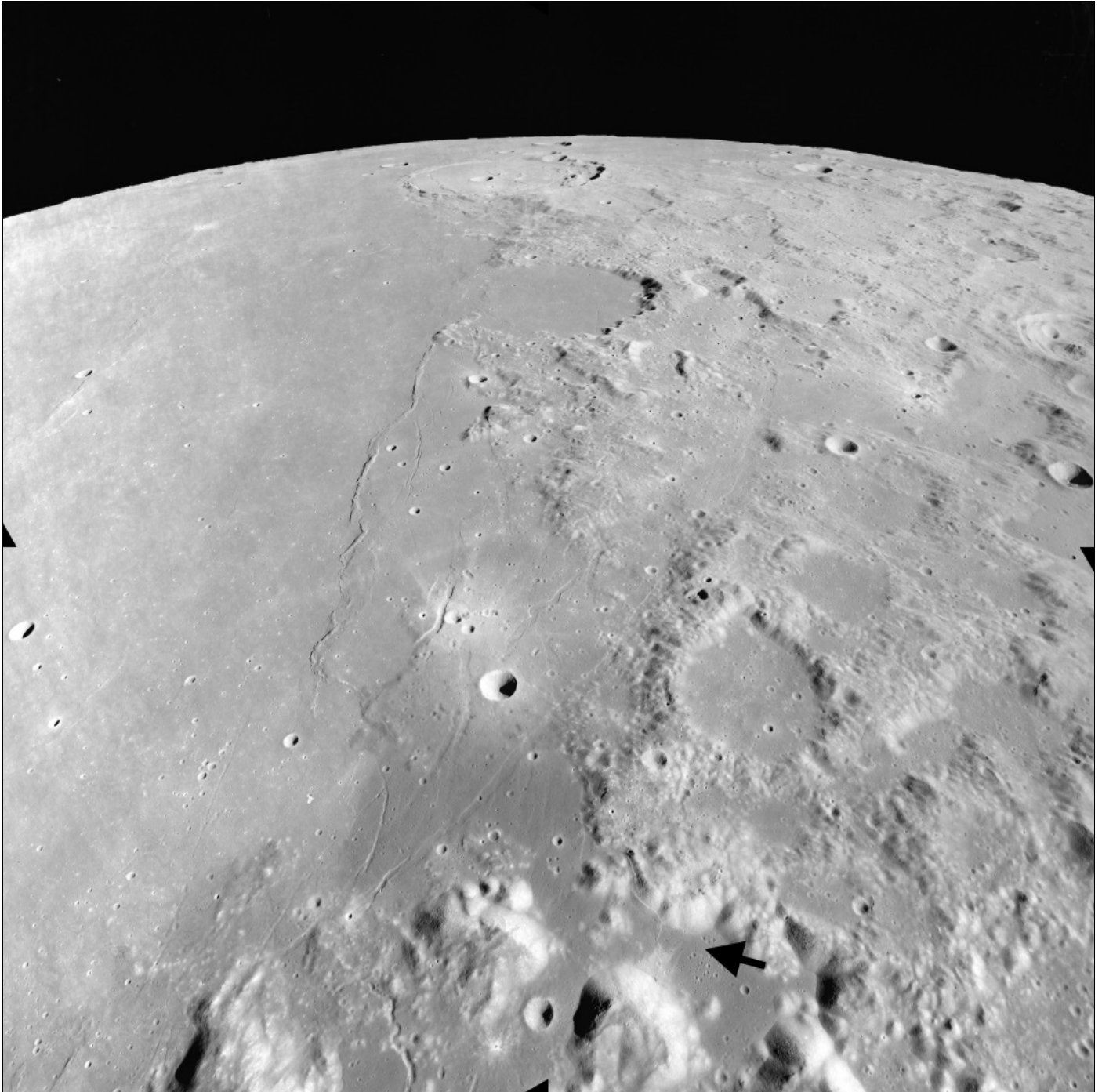

Figure 16: Apollo 17 Lunar Site – Vertical View. The arrow points to the landing site in the Taurus-Littrow Highlands and valley area. NASA photograph AS17-M-0447, taken Dec. 11, 1972. Digital image archived by NASA/JSC/Arizona State University at: http://wms.lroc.asu.edu/apollo/view?image_name=AS17-M-0447

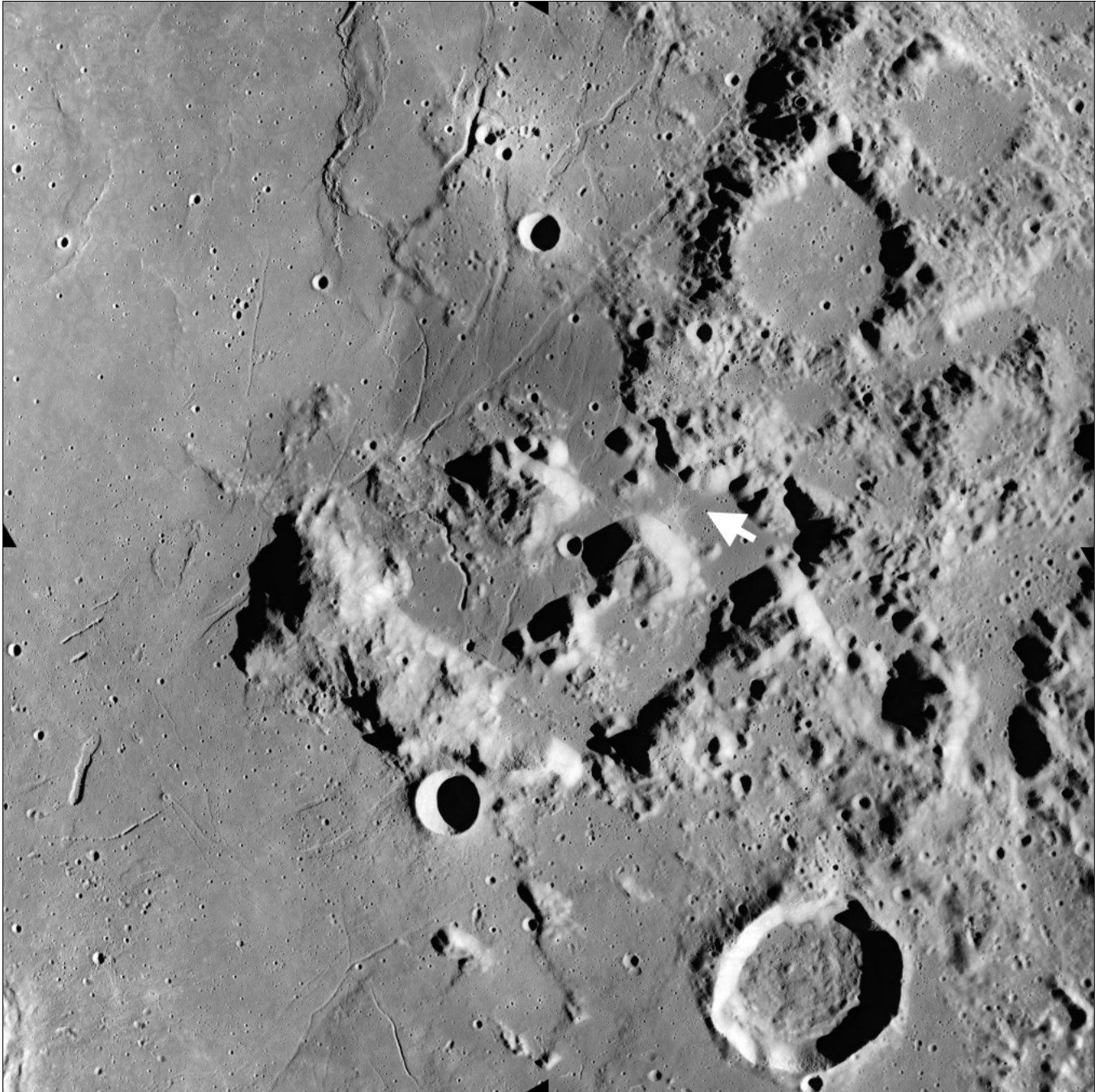

Figure 17: Apollo 17 Lunar Site – 2011. The arrows point to the visible remnants of the mission and LRV tracks. This image was taken by the Lunar Reconnaissance Orbiter (LRO). Image Credit: NASA/GSFC/Arizona State University, M168000580R. This and other LRO imagery at: http://www.lroc.asu.edu/featured_sites/#ApolloLandingSites

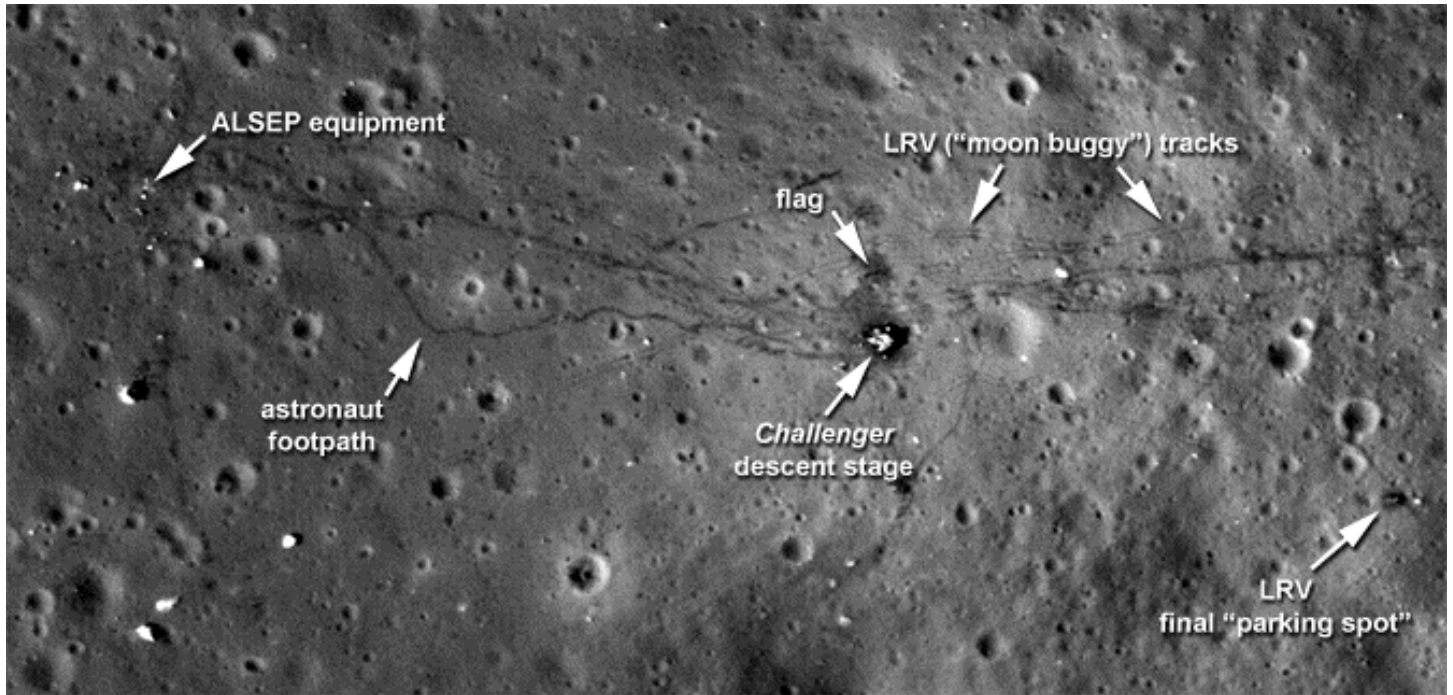
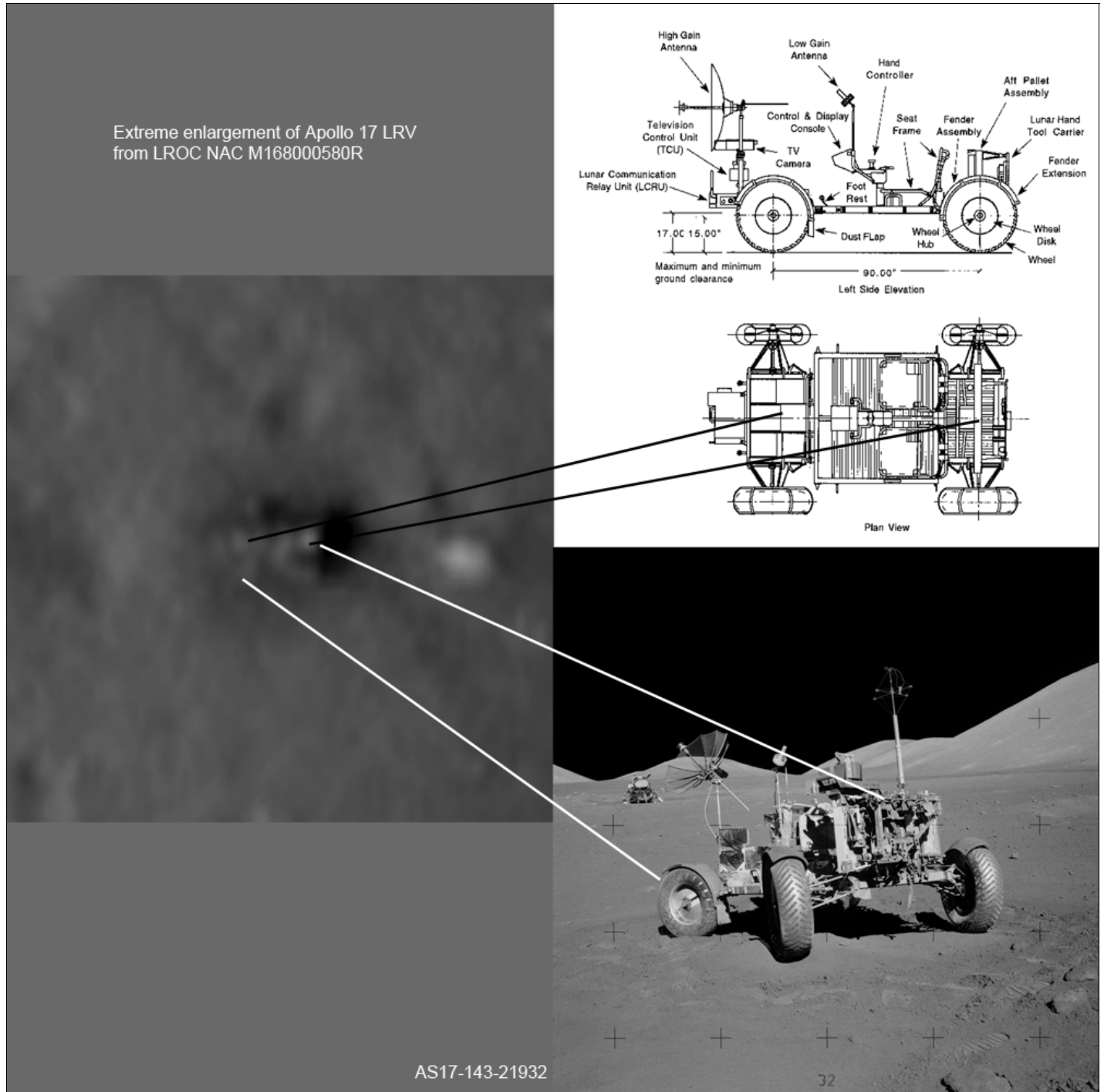

Figure 18: Extreme Enlargement of Apollo 17 LRV – 2011. The graphic shows an enlargement of the LRV (left), an image of the LRV in its final parking spot (bottom right), and a schematic of the LRV (upper right). The enlarged image was taken by the Lunar Reconnaissance Orbiter (LRO). Image Credit: NASA/GSFC/Arizona State University, M168000580R. This and other LRO digital images are archived by NASA/GSFC/Arizona State University at: http://www.lroc.asu.edu/featured_sites/#ApolloLandingSites



AS17-143-21932

32

Figure 19: Apollo 17 astronaut Eugene A. Cernan checks the LRV at the start of the mission's first EVA at the Taurus-Littrow landing site. The Challenger Lunar Module is in the background. The photograph was taken by scientist-astronaut Harrison H. Schmitt. *NASA photograph AS17-147-22527, taken Dec. 11, 1972.* Digital image archived by NASA at: <https://spaceflight.nasa.gov/gallery/images/apollo/apollo17/html/as17-147-22527.html>



Figure 20: Apollo 17 mission. The LRV sits parked on the lunar surface near the Taurus-Littrow landing site. NASA photograph AS17-146-22367, taken Dec. 1972. Digital image archived by NASA at: <https://spaceflight.nasa.gov/gallery/images/apollo/apollo17/html/as17-146-22367.html>



Figure 21: Apollo 17 astronaut Eugene A. Cernan approaches the parked LRV during the mission's third and final EVA. South Massif can be seen in the background. The photograph was taken by scientist-astronaut Harrison H. Schmitt. *NASA photograph AS17-134-20476, taken Dec. 13, 1972.* Digital image archived by NASA at: <https://spaceflight.nasa.gov/gallery/images/apollo/apollo17/html/as17-134-20476.html>



Figure 22: Apollo 17 – A close-up view of the LRV at the Taurus-Littrow landing site. Note the makeshift repair arrangement on the right rear fender of the LRV. Following a suggestion from astronaut John W. Young in the Mission Control Center at Houston the crewmen repaired the fender early in EVA-2 using lunar maps and clamps from the optical alignment telescope lamp. Schmitt is seated in the rover. Cernan took this picture. NASA photograph AS17-137-20979, taken Dec. 12, 1972. Digital image archived by NASA at <https://spaceflight.nasa.gov/gallery/images/apollo/apollo17/html/as17-137-20979.html>

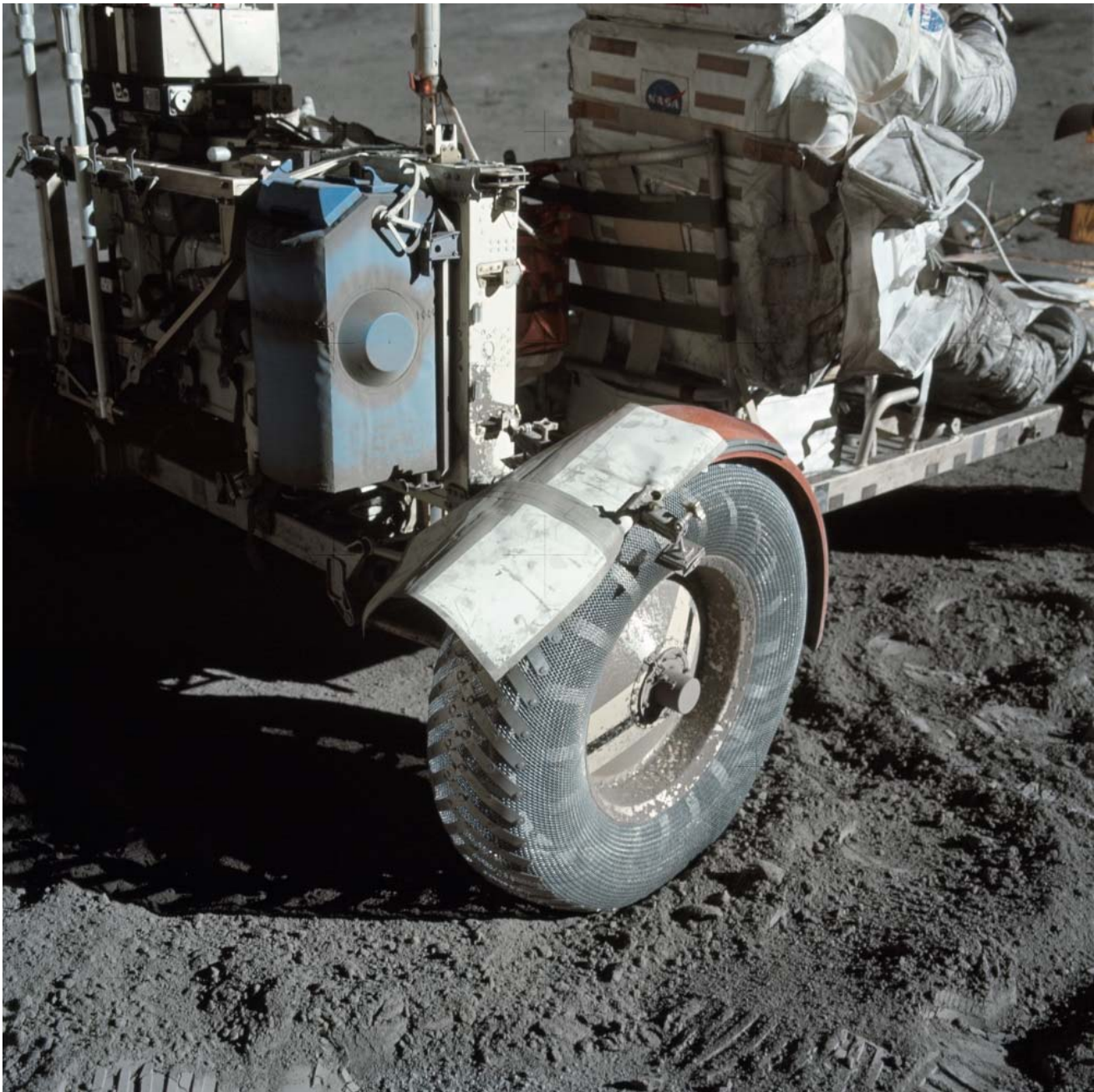

Figure 23: Apollo 17 – the LRV is shown in its final parking spot, with the LM in the background. By the time Eugene Cernan took this photograph, he had already removed the replacement fender at the right rear and, also, had removed the left rear fender extension. *NASA photograph AS17-143-21931, taken Dec. 13, 1972.* Digital image archived by NASA at: <https://www.flickr.com/photos/projectapolloarchive/21036715824>



Figure 24: Apollo 17 Traverse Map. The X marks the location of the Challenger Lunar Module. The dark lines indicate the paths taken by the astronauts in the LRV during the three EVAs. The numbers reference scientific sampling stations. Source: James R. Zimbelman, Lunar and Planetary Institute website: <https://www.lpi.usra.edu/publications/slidesets/apollolanding/>

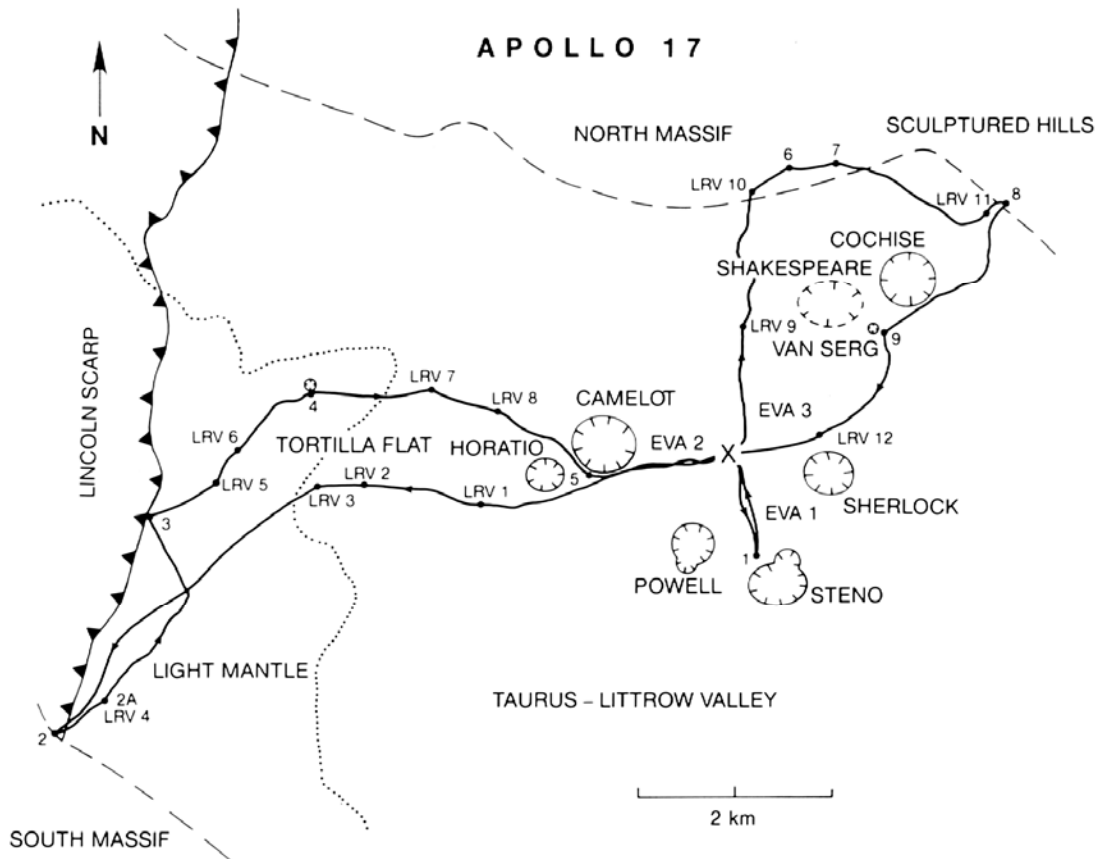

Figure 25: "Lunar Roving Vehicle – Spacecraft on Wheels [2-page flyer]." The Boeing Company, Industrial Relations, ca. 1971. The Boeing Company, Corporate Archives. Bellevue, WA.

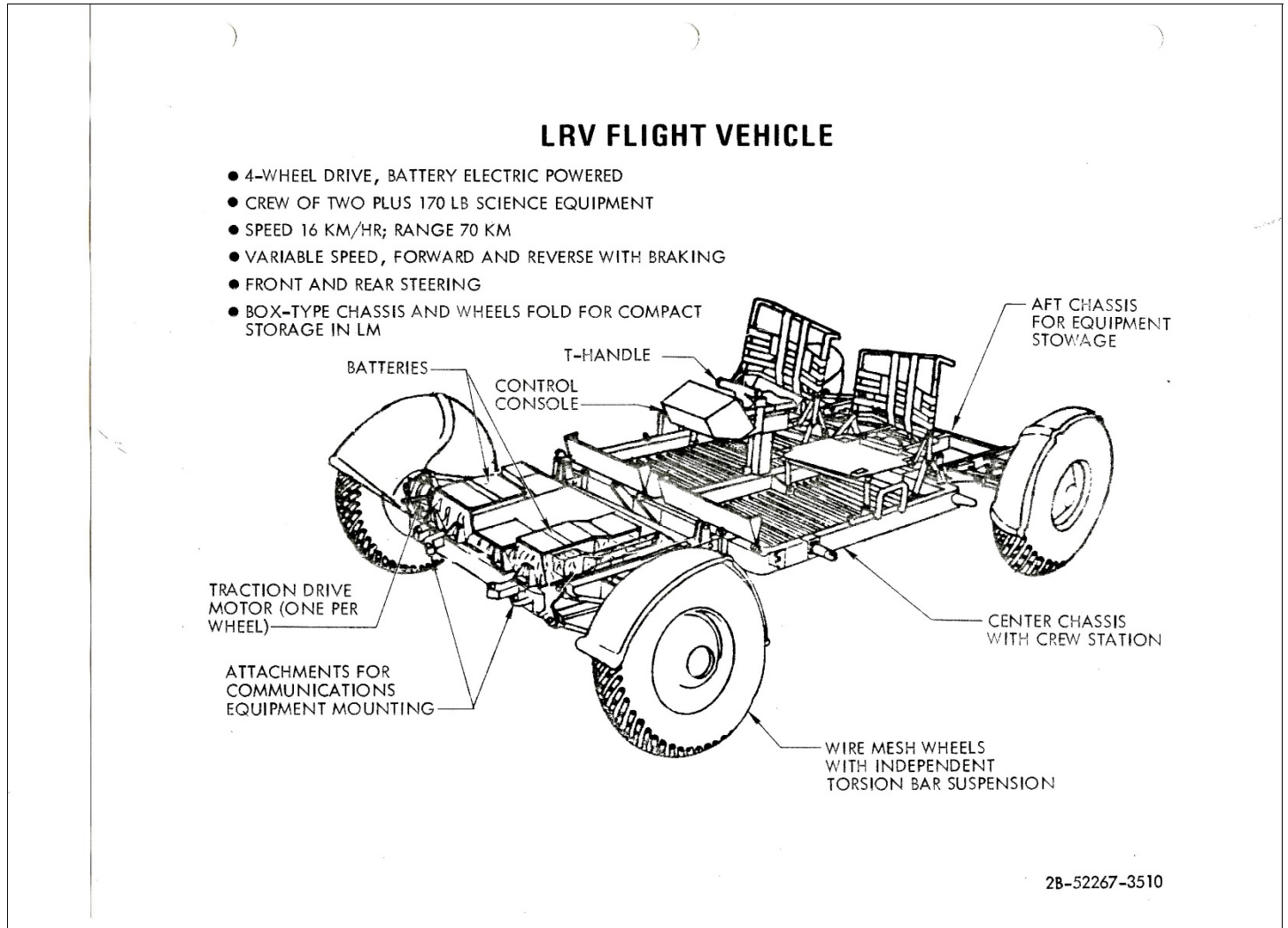

Figure 26: "LRV Detail Drawing." *Boeing News*, July 8, 1971, p. 3. A similar version of this detail drawing appeared on page 79 of NASA Press Kit for Apollo 15, Release no. 71-119K. Archived by NASA at: https://history.nasa.gov/alsj/a15/A15_PressKit.pdf

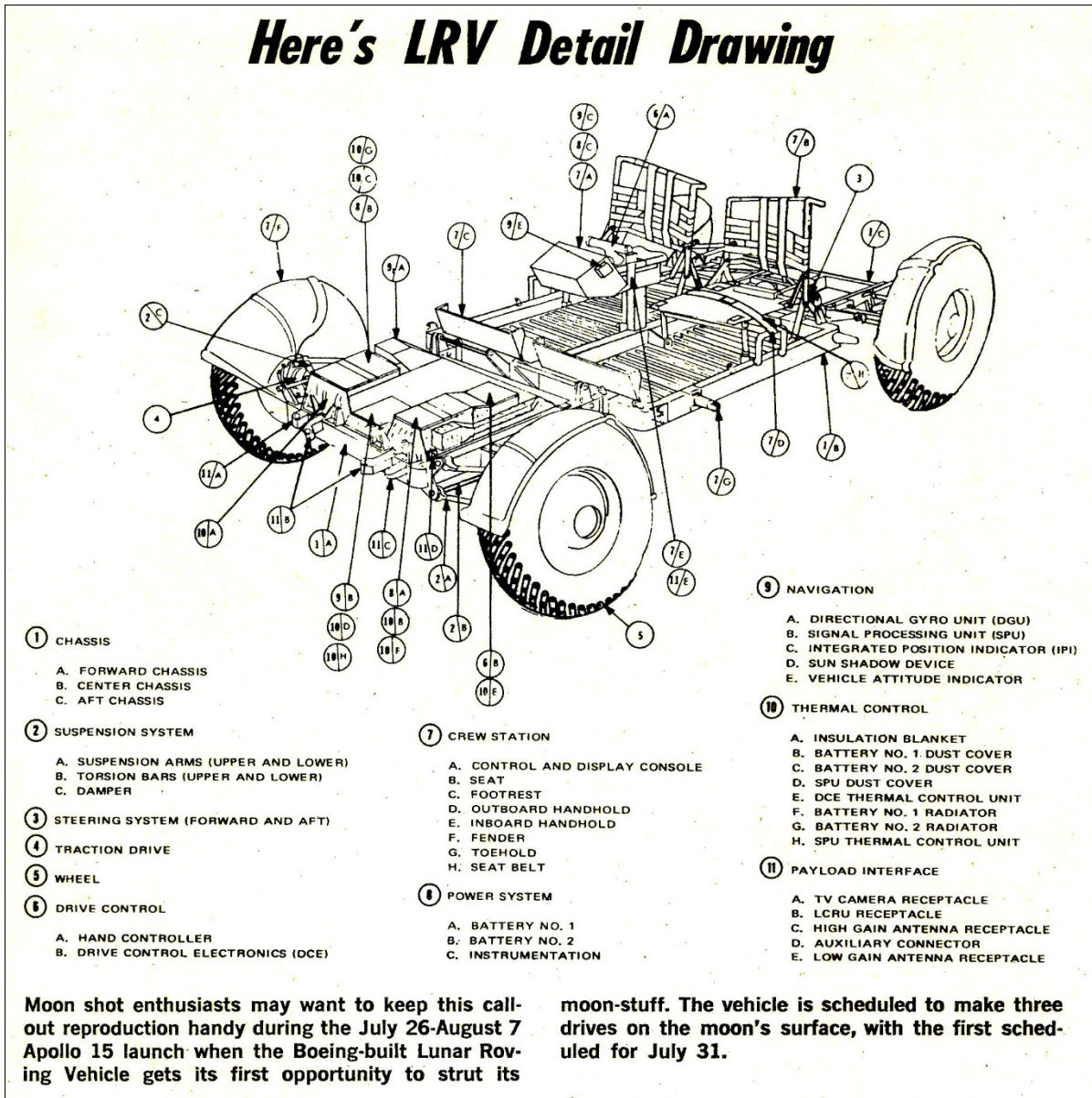

Figure 27: "LRV Components and Dimensions." NASA Press Kit for Apollo 15, Release no. 71-119K, p. 80. Archived by NASA at: https://history.nasa.gov/alsj/a15/A15_PressKit.pdf

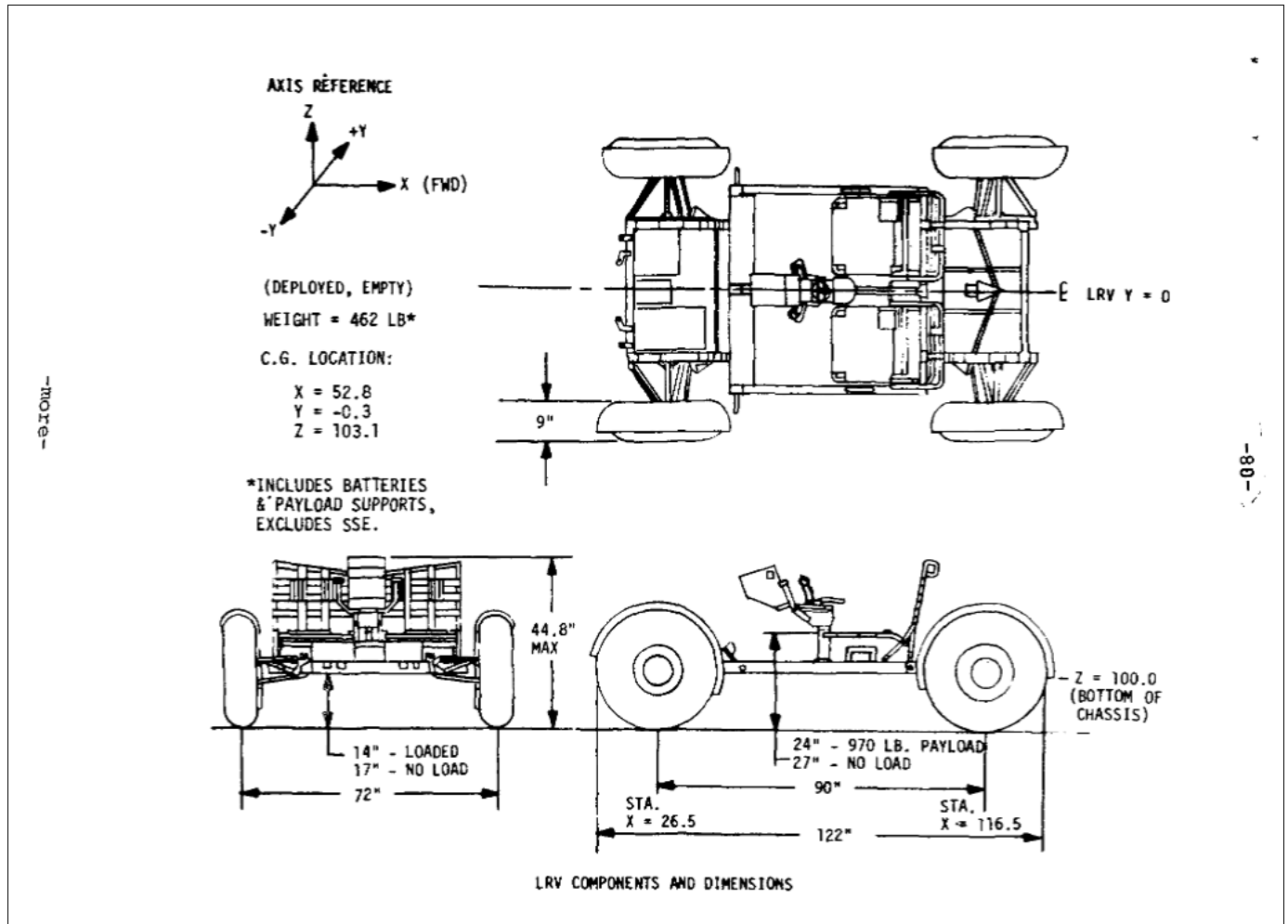

Figure 28: NASA-Marshall Space Flight Center. News release of LRV Line Drawing: LRV Stowed Payload Installation. Photo 0-10844. Release date March 1, 1971. The Boeing Company, Corporate Archives. Bellevue, WA.

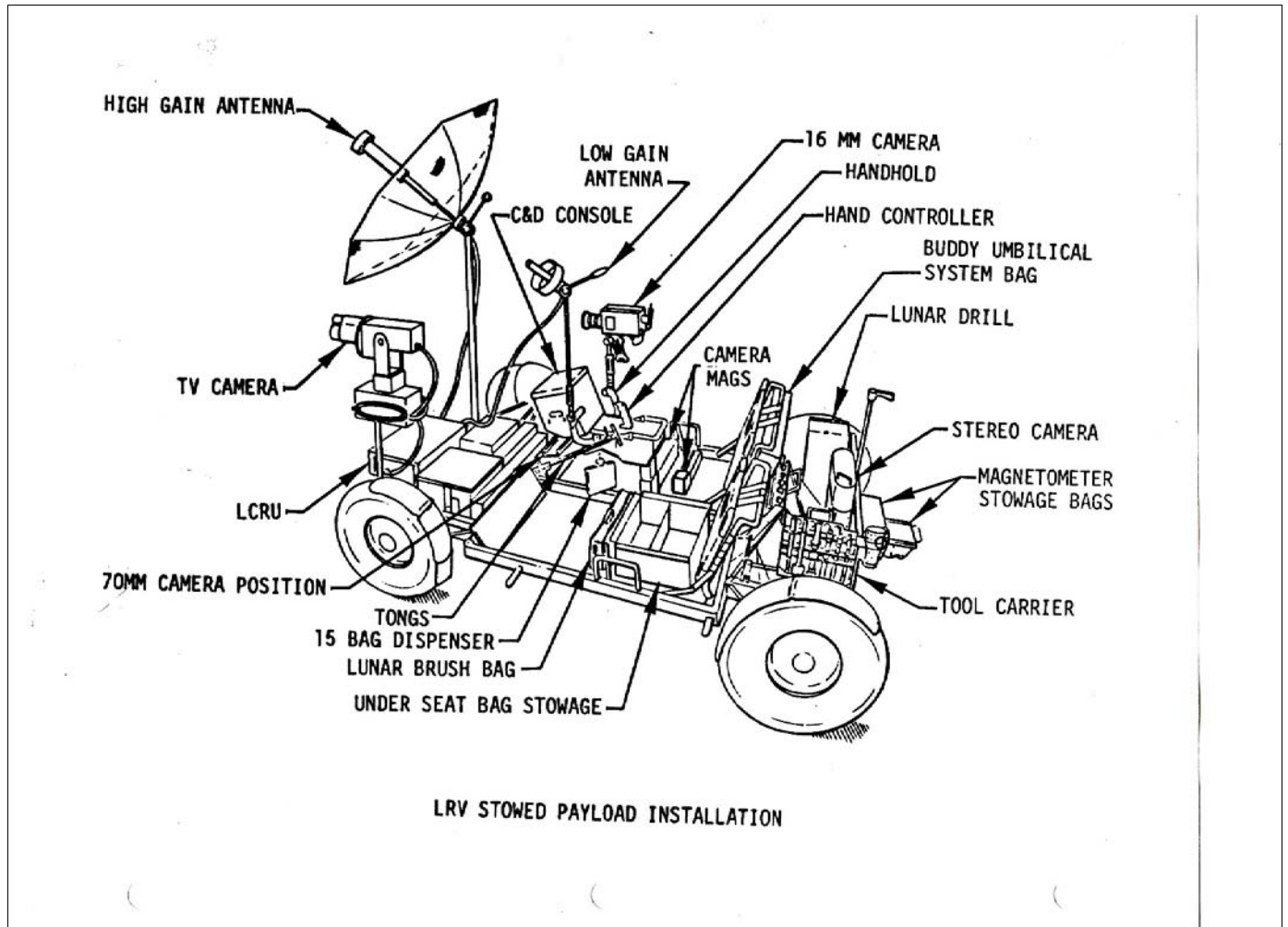

Figure 29: Lunar Roving Vehicle Shown Folded for Stowage on Spacecraft. Mar. 1971. 2A302135. The Boeing Company, Corporate Archives. Bellevue, WA.

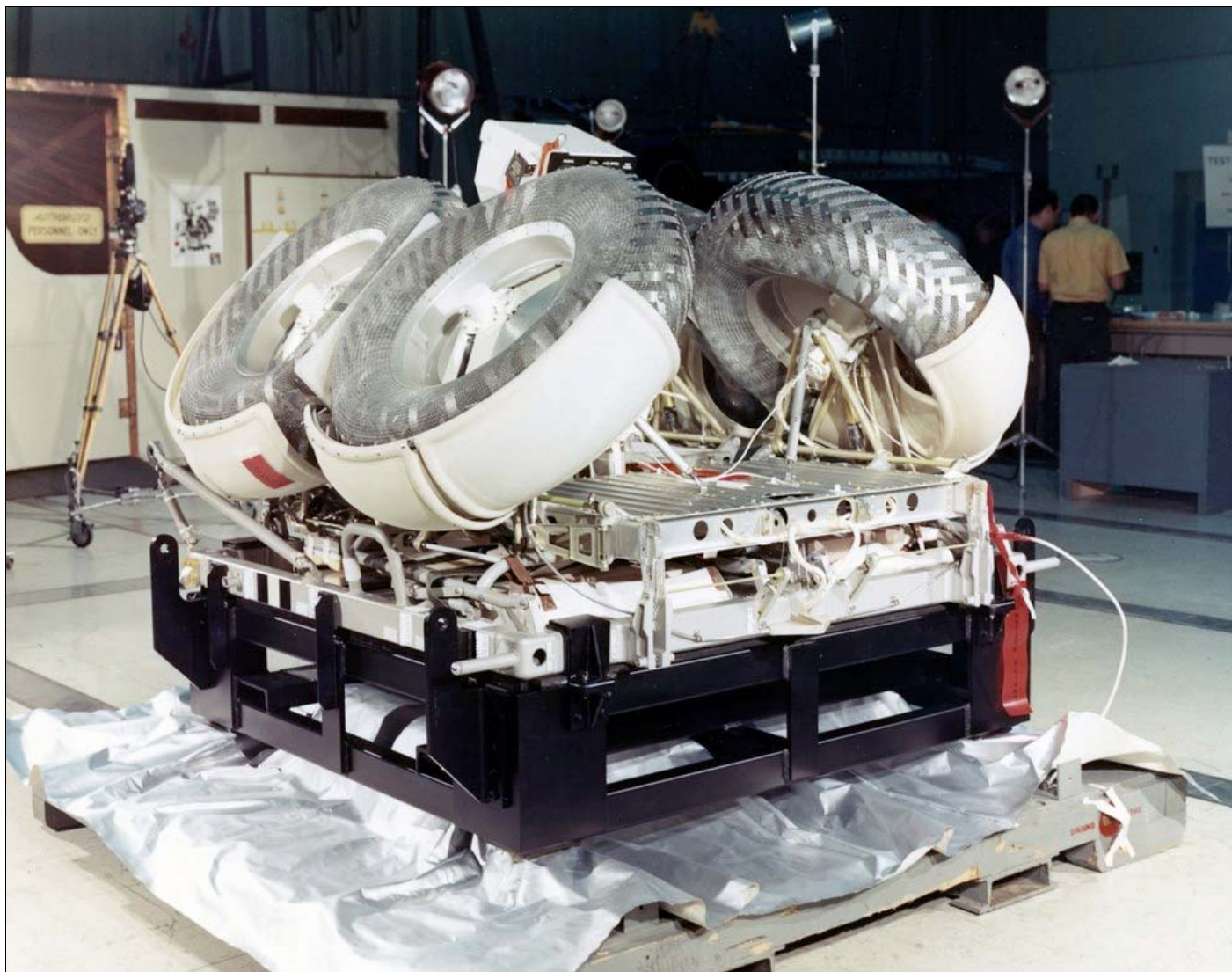

Figure 30: "LRV Deployment Sequence." The LRV was a collapsible, open-space vehicle measuring about 10 feet long with large mesh wheels, antenna, appendages, tool caddies, and cameras. NASA Press Kit for Apollo 16, Release no.72-64K, p. 117. Archived by NASA at: https://history.nasa.gov/alsj/a16/A16_PressKit.pdf

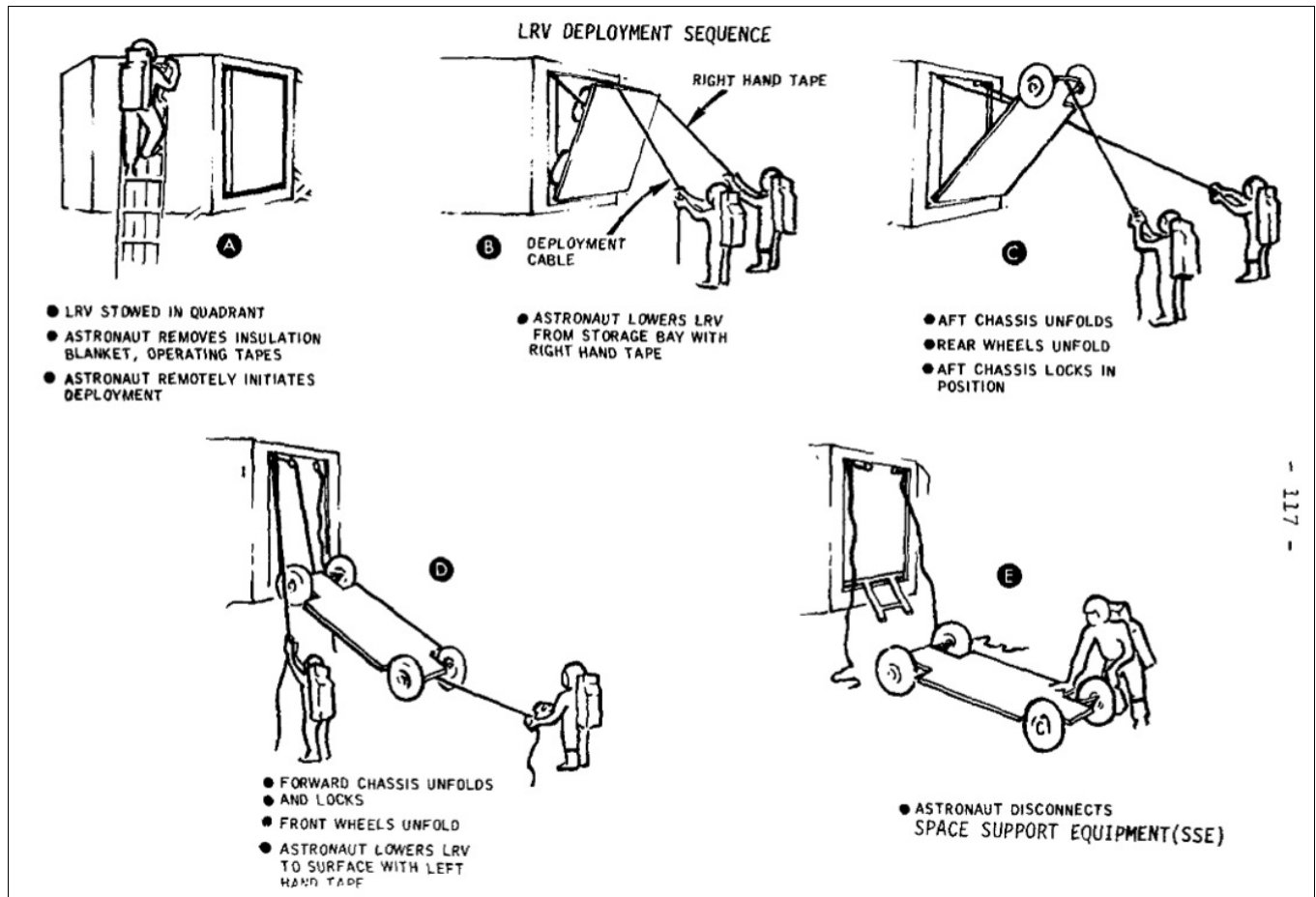

Figure 31: Boeing advertisement about the forthcoming Kent Space Center. *Kent News-Journal*, Aug. 19, 1964, Diamond Jubilee Edition, p. 5.

1964 News
1989 Diamond Jubilee Edition 1964
Page 5



*To help get
man to the moon,
we're bringing
the moon to Kent*

When the Boeing space flight laboratory moves into the new Kent research center next year, it will, in effect, bring the moon to Kent.

The space flight facilities, which have already helped train Air Force astronauts, include a simulator which projects television pictures of the moon's surface onto a bowl-shaped screen in front of the pilot's cabin. The pilot, using controls operating through a computer, can direct his craft on a life-like trip through space. The space-flight simulator is used to perform realistic lunar landings, lunar take-offs and re-entry into the earth's atmosphere.



Other Boeing space-research facilities destined for the Kent center include a space docking simulator, in which pilots practice orbital rendezvous techniques. The cabin is mounted on an air bearing which permits angular motion in any direction, making it possible to practice controlling a spacecraft in simulated flight.

These and other advanced space-oriented research programs will be underway in Kent next year, to help the nation put man on the moon and explore the universe of space.

BOEING

Figure 32: Boeing's new Space Center. *Boeing News*, Aug. 5, 1965, p. 1.

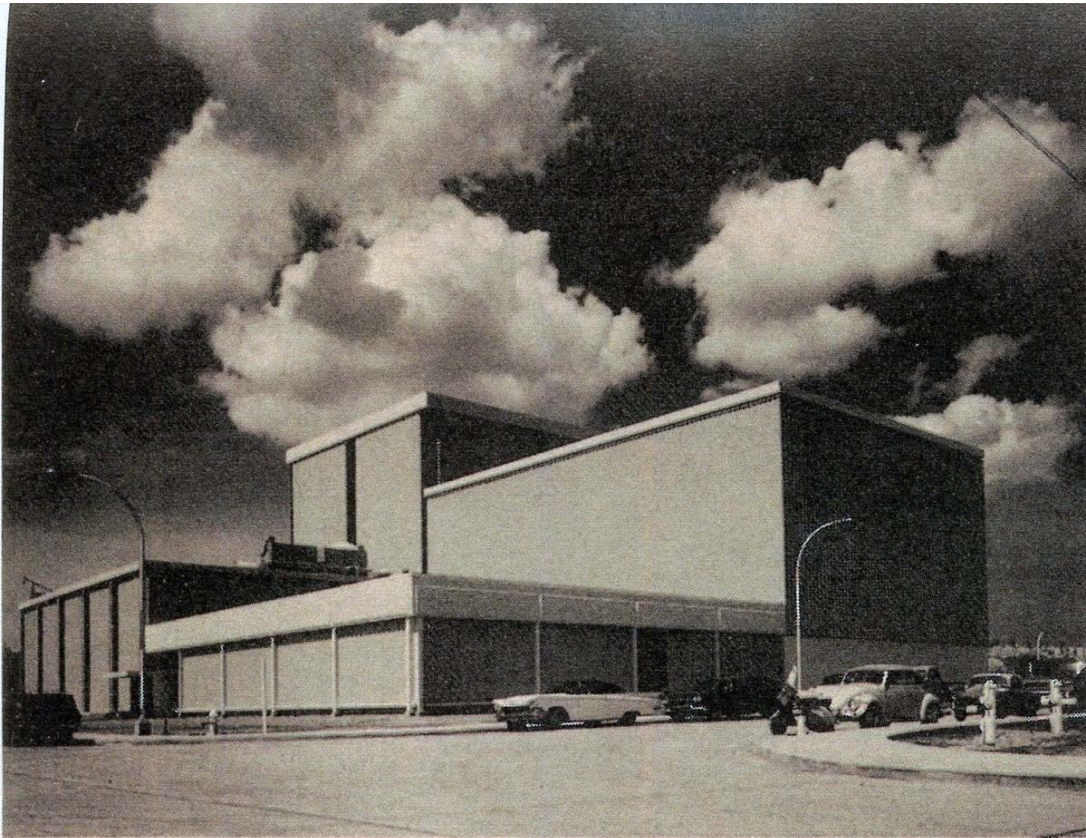

BOEING NEWS PHOTO BY DICK STEFANICH

Boeing's new Space Division will headquarter near the Space Simulation Laboratories building shown here following completion of the new building announced for the Boeing Space Center at Kent today. A two-story office building is the latest expansion step at the center. Use of infrared film and a red filter exaggerated the blackness of space stretching beyond the clean outlines of the buildings, perhaps symbolic because the building contains some of the industry's most modern facilities for space flight simulation and environment simulation.

Figure 33: Illustration of Boeing's MOLAB, a precursor to the lunar roving vehicle. It featured six wheels, a pressurized cabin, and it weighed nearly 8,000 pounds. *Boeing News*, Jun. 3, 1965, p. 4.

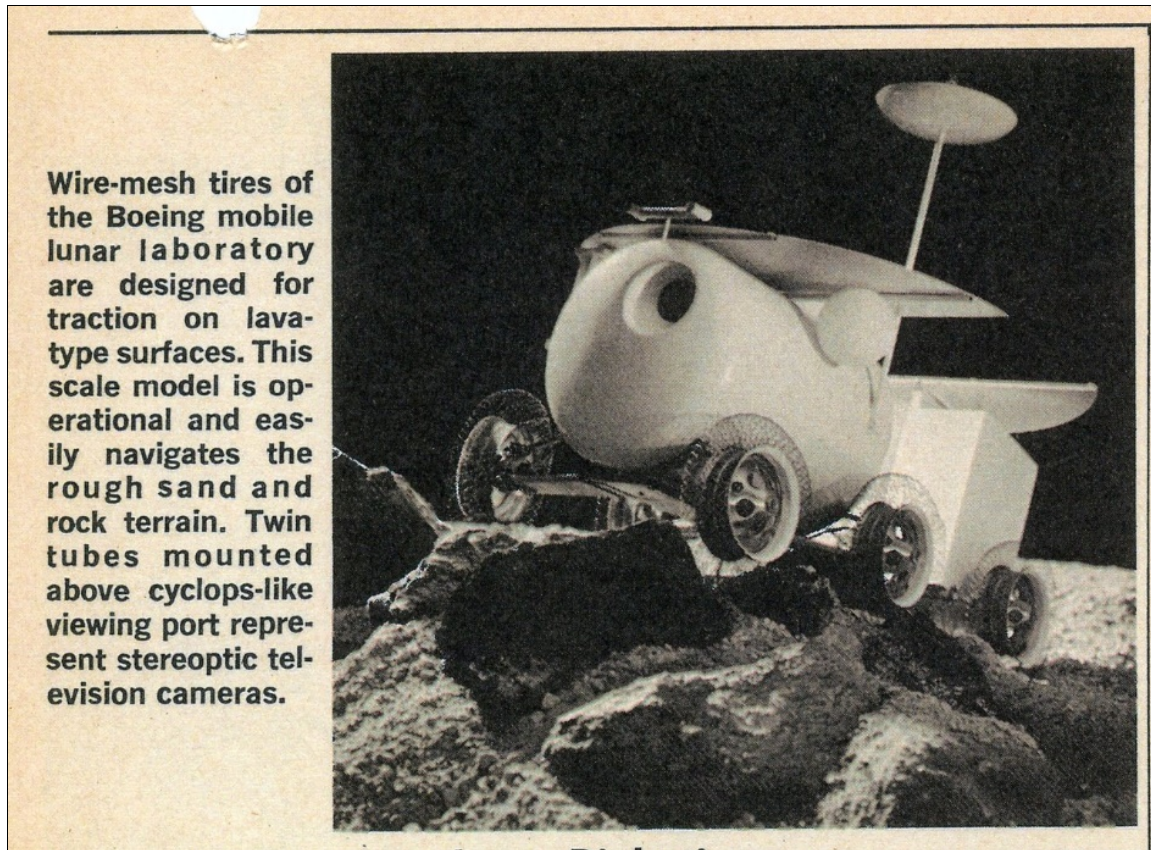

Figure 34: Sharron Scott, a secretary in Boeing's Kent-based LRV program, is shown in this promotional photograph for the rover. The accompanying action memo was signed by Boeing public relations staff Jim Grafton and Jack Wecker with the instruction not to release the photo until July 31, 1971 – after the launch of Apollo 15. Subsequent publication of the photo in newspapers has not been found. Photograph P47742, The Boeing Company, Corporate Archives. Bellevue, WA.

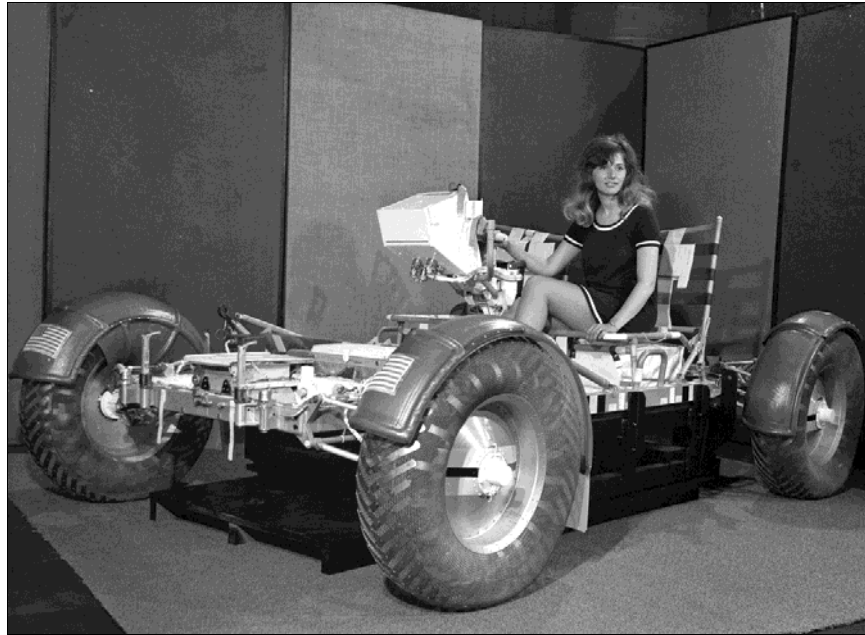

Figure 35: LRV program secretary Judy Williams is shown below. *Boeing News*, Mar. 11, 1965, p. 1



—BOEING NEWS PHOTOS BY VEEN KUTLEDGE

The space environment simulation laboratory at Kent is nearing completion. The building was first occupied by permanent tenants Monday, first test activity is due in late summer. The lab building houses the 39-ft. by 50-ft. space simulation chamber and other space experiment equipment. At right is Judy Williams, first woman into space lab.

First Unit Moves Into Kent Center; Tests By Autumn

Judy Williams has had no lack of help this week. When she has needed assistance, one of nearly 150 men has been on hand to offer his help.

Judy moved to Boeing's Kent facility Monday, as did members of her organization. They are the first permanent tenants on the site and Judy is the only girl among them. Judy (more formally Mrs. Williams) is secretary to John Van Bronkhorst, space environment simulation laboratory manager.

A half dozen members of Van Bronkhorst's group have been relocated at Kent for the "shake-down" stage of construction. They will use the 39-foot diameter space simulation chamber and other equipment housed in the space laboratory building. The final determination as to the equipment's readiness is theirs.

Contractor crews and Boeing facilities personnel are rushing the building toward completion in anticipation of tests in early fall. Other personnel will move to the facility as construction progresses.

BOEING

VOL. 24, NO. 10 PUBLISHED

Two Airlines P

Sales of additional 707s to two airlines have been confirmed by The Boeing Company.

South African Airways has announced government approval of

Figure 36: The first complete LRV, seen in the bottom photo on March 10, 1971, the day Boeing officially transferred it to NASA. Photograph 2A302169, The Boeing Company, Corporate Archives. Bellevue, WA. The newspaper article is from *Boeing News*, March 18, 1971, p. 1.

NASA receives first Lunar Rover Vehicle

The Boeing-built Lunar Roving Vehicle, which will be the first machine to transport men on the moon's surface, is at Cape Kennedy being readied for space flight. The moon buggy was flown to Florida Monday following a symbolic delivery to the National Aeronautics and Space Administration last week at the Boeing Space Center.

At Cape Kennedy the rover will undergo final checkout and processing before being loaded aboard the huge Saturn V rocket which will send it to the moon with the Apollo 15 astronauts in July.

The unique vehicle was accepted for NASA by Dr. Eberhard Rees, director of the Marshall Space Flight Center at Huntsville, Alabama. Rees told a crowd of Boeing officials, technical people who had assembled the vehicle and guests, "You have reason to be proud.

"It took hard work, dedication and skill to make up the time lost as a result of the technical problems which arose during the early stages of the program." Noting that the LRV was ready two weeks ahead of scheduled delivery, he said, "This is quite an accomplishment, considering the early problems.

"You of Boeing and your subcontractors are due much credit. Had you not made your schedule, the Apollo program planning would have been seriously upset."

Dr. Rees said the first LRV, and the two to follow, would make future Apollo missions many times more effective than past missions because of the astronauts' increased mobility.

Dr. Rees was presented the rover's license plate, LRV-001 by O. C. Boileau, group vice president—acrospace. Boileau also paid tribute to the drive and leadership of the late George Stoner, senior vice president—operations, for his efforts in the program.

The ceremony was held in the shadow of the big space simulation chamber, where part of the LRV testing was done. Ceremonies were opened by H. J. McClellan, Space Division manager.

Addressing the engineers and technicians in attendance, McClellan said, "To the many of you who have not had a day off work since November, except for Christmas and New Year's, I want to say that I am very proud of your accomplishment."

The LRV is a 480-pound, four-wheeled vehicle that can carry two astronauts over the moon's rough surface at about eight miles an hour. It can climb slopes of up to 20 degrees, and can operate in the vacuum, deep cold and high heat found in space.

The craft has been built to



Initial LRV sported bright new license plate at ceremony where NASA accepted the moon buggy.

the exacting requirements of all Apollo program hardware, and has undergone a development qualification and acceptance test procedure to qualify it as a manned spacecraft.

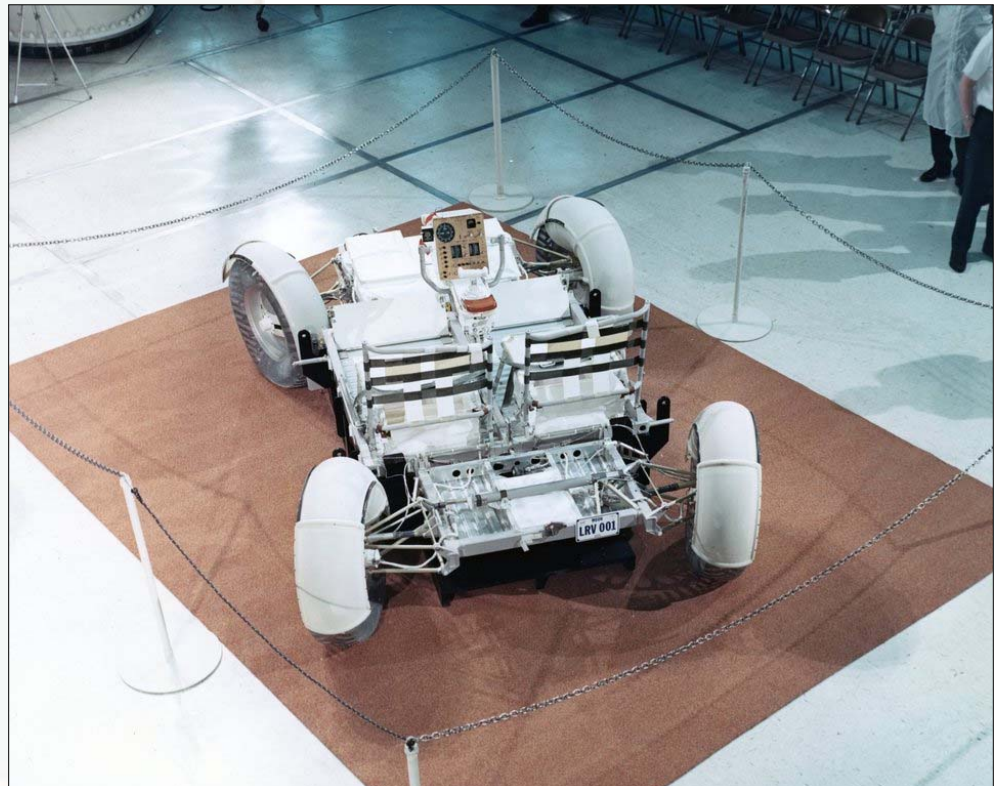
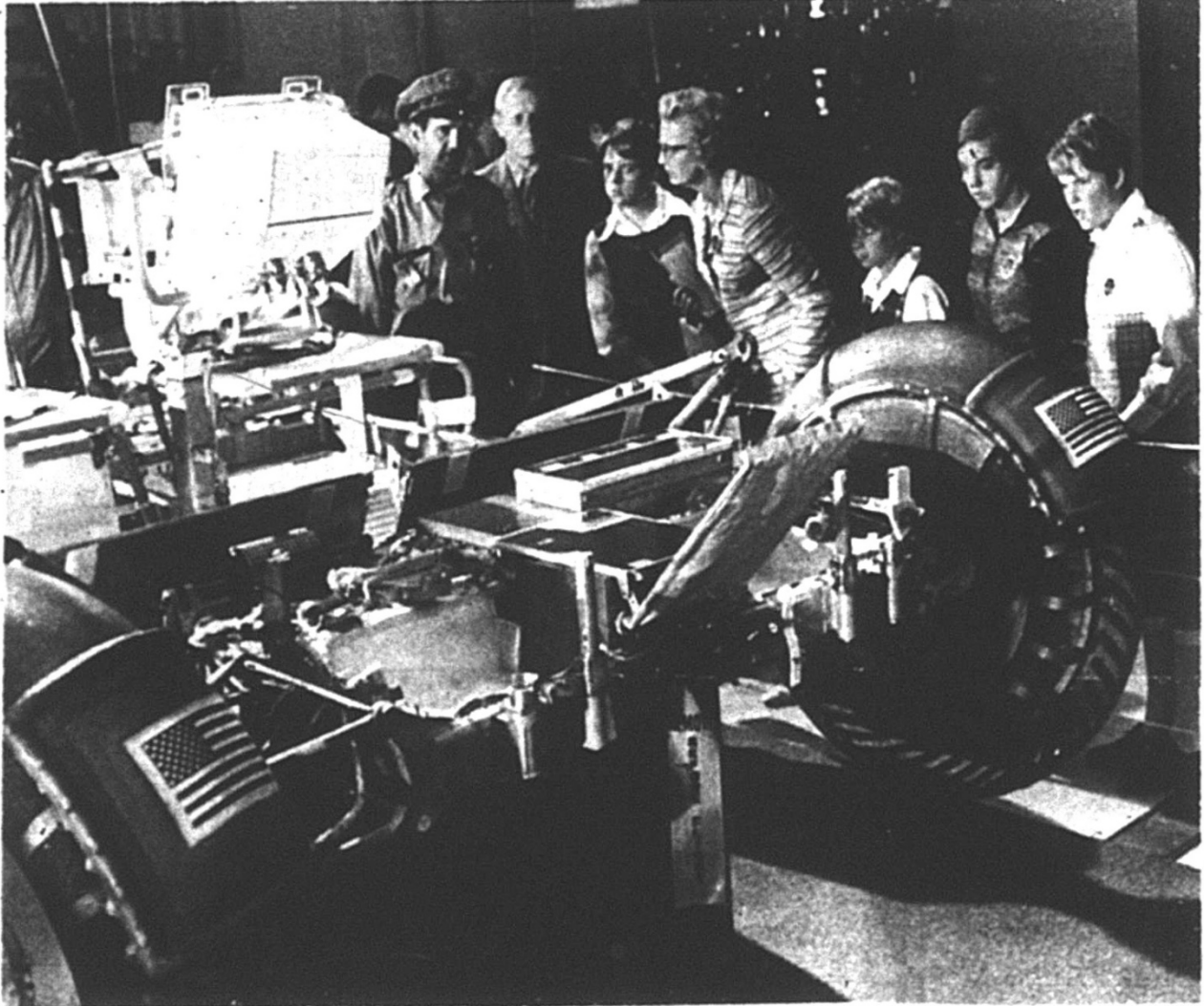

Figure 37: Mayor Isabel Hogan examines Boeing's Rover 2 during the unveiling ceremony at the Kent Space Center. *Kent News-Journal*, Aug. 18, 1971, p. 1.



Lunar rover examined by mayor

Kent Mayor Isabel Hogan, center, in striped jacket, leaned forward intently as she and her children examined the Lunar Vehicle that will go to the moon on Apollo 16. Almost out of the picture far left is Dennis

Hogan. From left of an unidentified guard and Boeing Co. official Hal McClellan are Sharon, Mrs. Hogan, Judy, Carol and Barbara Hogan. Mrs. Hogan's older son, Mike, was unable to make the tour.

Figure 38: Kendall Brookbank, age 10, stands beside a tinfoil replica rover. *Kent News-Journal*, Jul. 28, 1971, p. 3.



Figure 39: The Kent Jaycees sold these blue and white buttons reading *Kent, Washington – Home of the Boeing Moon Buggy* as a fundraising project in the fall of 1971.



Figure 40: Boeing's R. H. Nelson receives one of the Jaycee's buttons from Kent Chamber representative Hal Barrentine. *Kent News-Journal*, Oct. 15, 1971, p. 8.

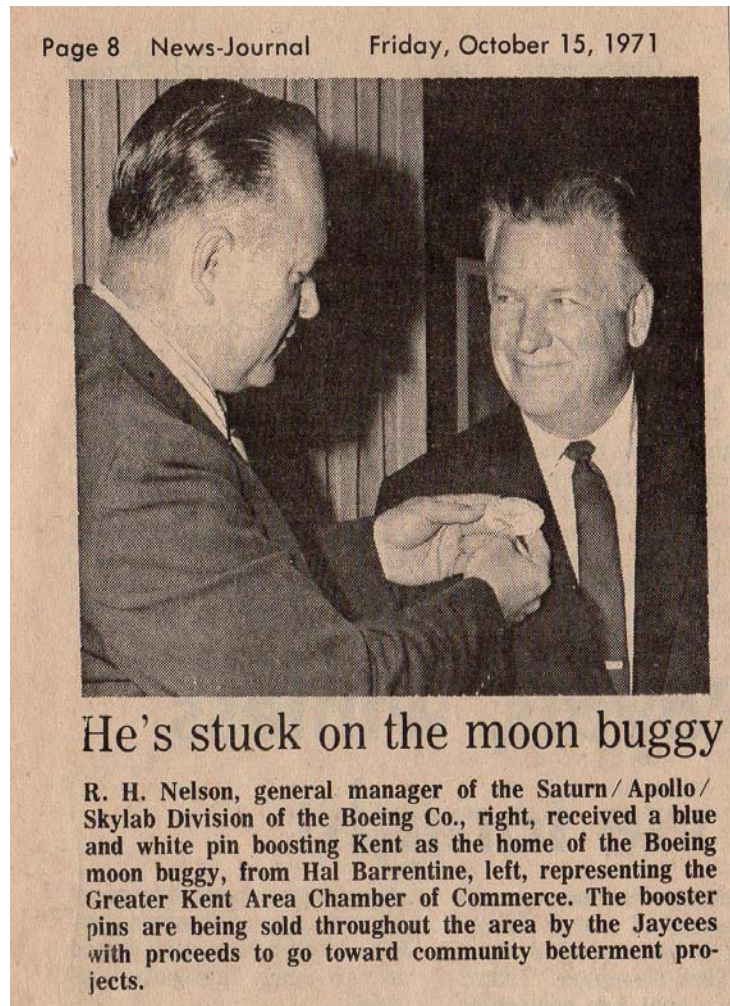

Figure 41: Table showing Lunar Roving Vehicle performance during Apollo 15, 16, and 17 missions. Source: National Aeronautics and Space Administration (NASA). *Apollo Program Summary Report (JSC-09423)*. Houston, TX: Lyndon B. Johnson Space Center, April 1975, p. 4-101. Accessed Feb. 22, 2019. <https://www.hq.nasa.gov/alsj/APSR-JSC-09423.pdf>

TABLE 4-IX.- LUNAR ROVING VEHICLE PERFORMANCE

Values	Apollo 15	Apollo 16	Apollo 17
Drive time, hr:min	03:02	03:26	04:29
Surface distance traveled, km . . .	27.9	26.7	33.8
Extravehicular activity duration, hr:min	^a 18:35	20:14	22:04
Average speed, km/hr	9.2	7.7	7.6
Energy rate, A-h/km (lunar roving vehicle only)	1.9	2.1	1.64
Ampere-hours consumed (242 available)	52.0	88.7	73.4
Navigation closure error, km	0.1	0	0
Number of navigation updates	1	0	0
^b Maximum range from lunar module, km	~4.4	~4.6	~7.3
Longest extravehicular activity traverse, km	12.5	11.4	18.9

^aDoes not include standup extravehicular activity time of 33 minutes 7 seconds.

^bMap distance measured radially.

PART IV: MAJOR BIBLIOGRAPHICAL REFERENCES

9. Previous Documentation

Use the space below to cite the books, articles, and other sources used in preparing this form (use continuation sheet if necessary).

Previous documentation on file:

- included in King County Historic Resource Inventory # Multiple
- previously designated a King County Landmark #47
- previously designated a Community Landmark
- listed in Washington State Register of Historic Places
- preliminary determination of individual listing
- (36 CFR 67) has been requested
- previously listed in the National Register
- previously determined eligible by the National Register
- designated a National Historic Landmark
- recorded by Historic American Buildings, Survey #:
- recorded by Historic American Engineering, Rec. #:

Primary location of additional data:

- State Historic Preservation Office
- Other State agency
- Federal agency
- King County Historic Preservation Program
- Local government
- University
- Other (specify repository)
The Boeing Co., Bellevue, WA
NASA libraries (online)
Museum of Flight, Seattle, WA

Bibliography

Atkins, Harris (Retired Engineer, LRV Program, Boeing). "Bring the Moon to Downtown Kent." Interview by Michelle Wilmot and Edgar Riebe, City of Kent, May 9, 2018. Accessed October 15, 2018. <https://vimeo.com/272473790>.

Bauer, E. E. *Boeing: The First Century*. Enumclaw, WA: TABA Publishing, 2000.

The Boeing Company website. "Apollo Lunar Spacecraft: Historical Snapshot." Accessed January 25, 2019. <https://www.boeing.com/history/products/apollo-lunar-spacecraft.page>.

The Boeing Company, Corporate Archives. Bellevue, WA.

The Boeing Company. "Lunar Roving Vehicle [25-page booklet]." Undated [ca. 1972].

The Boeing Company, Aerospace Group. "Organization Bulletin: Transfer of Lunar Roving Vehicle Qualification Vehicle and Flight Vehicle Assembly." September 3, 1970.

The Boeing Company, Aerospace Group. "Organization Bulletin: Lunar Roving Vehicle / Apollo Program Relationships." November 3, 1970.

The Boeing Company, Industrial Relations. *Lunar Roving Vehicle – Spacecraft On Wheels* [2-page flyer]. Undated.

The Boeing Company, LRV Systems Engineering. *Lunar Roving Vehicle Familiarization*. June 3, 1971.

NASA-Marshall Space Flight Center. News release of LRV Line Drawing: LRV Stowed Payload Installation. Photo 0-10844. Release date March 1, 1971.

Photograph Collection

Lunar Roving Vehicle Shown Folded For Stowage on Spacecraft. Mar. 1971. 2A302135.
Lunar Roving Vehicle Ready for Moon Journey. Mar. 1971. 2A302169.
Sharron Scott, Boeing Secretary, Poses In LRV. No date. P47742.

The Boeing Company. Lunar Roving Vehicle Engineering Mock-up. Constructed 1971. Museum of Flight Museum Collections, Seattle, WA. Personal visit and online. Accessed October 15, 2018.
<http://www.museumofflight.org/spacecraft/boeing-lunar-roving-vehicle-engineering-mock>.

[No Author] "Boeing Gets \$20 Million Apollo Integration Job." *Roundup* 6, no. 8 (June 23, 1967): 1.
[Publication of NASA's Manned Space Center, Houston, TX]

[No Author] "The Boeing Lunar Rover will be the First Car on the Moon." *Boeing Magazine* 40: No. 2 (February 1970): 12-14.

Boeing News.

"New Space Laboratories Planned at Kent Site." February 6, 1964.
"First Unit Moves into Kent Center; Tests by Autumn." March 11, 1965.
"Compact Car for Moon Tourists Also Their Home on Wheels." June 3, 1965.
"Stripped-Down Moon Buggy for Scientific Survey Studied." July 15, 1965.
"New Kent Headquarters for Space Division Announced." August 5, 1965.
Koch, Roger. "Sophisticated Lunar Rover Vehicle More Than A 'Tough Jeep.'" December 4, 1969.
"Lunar Rover Features Electric Drive Wheels, Swivel Seats." December 11, 1969.
"Rover Program Moves Forward." June 25, 1970.
"For Apollo 15." February 4, 1971.
"NASA Receives First Lunar Rover Vehicle." March 18, 1971.
"LRV Detail Drawing." July 8, 1971.
"Astronauts Praise Near Perfect Show by Lunar Vehicle." August 5, 1971.
Naucner, Cindy. "Boeing Engineers Rebuild a Piece of Apollo History." May 5, 1995.

Burgess, Colin, and Chris Dubbs. *Animals in Space: From Research Rockets to the Space Shuttle*. New York: Springer Publishing, 2007.

Burkhalter, Bettye B., and Mitchell R. Sharpe. "Lunar Roving Vehicle: Historical Origins, Development and Deployment." *Journal of The British Interplanetary Society* 48 (1995): 199-212.

Clothier, William. "New Space Center Sharpens the Forward Edge of Research." *Boeing Magazine* 30, No. 10 (October 1965): 3-5.

Cernan, Eugene, and Don Davis. *The Last Man on the Moon: Astronaut Eugene Cernan and America's Race in Space*. New York: St. Martin's Press, 1999. [Cernan was part of Apollo 17]

Chaikin, Andrew. *A Man on the Moon: The Voyages of the Apollo Astronauts*. New York: Penguin Books, 2007.

Kent News-Journal

- "Space Labs to be Built This Year." February 5, 1964.
"Kent...Space Age City." [Diamond Jubilee Edition, multiple articles] August 19, 1964.
"Aero Structures to Bring 100+ Employees [sic] to Kent." September 15, 1965.
"Boeing Receives \$19 Million Contract for Moon Vehicles." October 31, 1969.
"County to Seek U.S. Cash, Cities to Act on Layoffs." January 16, 1970.
Carter, Wini. "Astronauts Blastoff with Moon Buggy." July 28, 1971.
"No Ordinary Car." July 28, 1971.
"Kent Space Center Employment 'Stable.'" August 11, 1971.
"Moon Riders Return Home." August 11, 1971.
"Apollo 16 Lunar Roving Vehicle Unveiled at Kent Space Center." August 18, 1971.
"Moon Buggy Buttons Go Over Big, Say Jaycees." October 13, 1971.
Carter, Wini. "3 Astronauts Tour Center." October 15, 1971.
"He's Stuck on the Moon Buggy." October 15, 1971.
"Boeing Opens Kent Lab Service to Industries." April 19, 1972.

Jones, Eric M., and Ken Glover, eds. *The Apollo Lunar Surface Journals*. [An online journal hosted by NASA that features original transcripts, video clips, photographs, subsequent reports, etc.] Accessed Nov. 1, 2018: <https://history.nasa.gov/alsj/main.html>.

Kennedy, John F. Special message to Congress on urgent national needs, 25 May 1961. Papers of John F. Kennedy. Presidential Papers. President's Office Files. Speech Files. Accessed November 9, 2018. <https://www.jfklibrary.org/asset-viewer/archives/JFKPOF/034/JFKPOF-034-030>.

Kershner, Jim. "Boeing and Washington's Aerospace Industry, 1934-2015." *HistoryLink.org Online Encyclopedia of Washington State History*, Essay #111111, 2015. Accessed Oct. 15, 2018: <http://www.historylink.org/File/111111>.

Kudish, Henry. "The Lunar Rover." *Spaceflight: A Publication of The British Interplanetary Society* 12, no. 7 (July 1970): 270-274. [Kudish was Boeing's LRV Program Manager.]

Laursen, Lucas. "The Moon Belongs to No One, but What About Its Artifacts?" *Smithsonian.com*. December 13, 2013. Accessed February 22, 2019. <https://www.smithsonianmag.com/science-nature/the-moon-belongs-to-no-one-but-what-about-its-artifacts-180948062/>.

Lentz, Florence K. *Kent: Valley of Opportunity*. Chatsworth, CA: Windsor Publications, Inc., 1990.

Lombardi, Michael. Corporate Historian, The Boeing Company. Personal Communication, Fall 2018.

Lyons, Richard D. "Jeep Will Introduce Traffic to Moon." *The New York Times*. November 9, 1969.

Morea, Saverio F. "The Lunar Roving Vehicle, A Historical Perspective." *The Second Conference on Lunar Bases and Space Activities of the 21st Century* NASA Conference Publication 3166, vol. 2

(1992): 619-632. Accessed October 15, 2018.

https://history.msfc.nasa.gov/lunar/LRV_Historical_Perspective.pdf [Morea was NASA's LRV Program Manager.]

National Aeronautics and Space Act of 1958, As Amended. Accessed March 1, 2019.

<https://history.nasa.gov/spaceact-legishistory.pdf>.

National Aeronautics and Space Administration (NASA). *Apollo 15 Mission Report, MSC-05161*.

December 1971. Accessed February 21, 2019. <https://www.hq.nasa.gov/alsj/a15/ap15mr.pdf>.

_____. *Apollo 15 Press Kit, Release no. 71-119K*. July 1971. Accessed December 28, 2018,

https://history.nasa.gov/alsj/a15/A15_PressKit.pdf.

_____. *Apollo 16 Mission Report, MSC-07230*. August 1972. Accessed February 21, 2019.

https://www.hq.nasa.gov/alsj/a16/A16_MissionReport.pdf.

_____. *Apollo 16 Press Kit, Release no. 72-64K*. April 1972. Accessed December 28, 2018.

https://history.nasa.gov/alsj/a16/A16_PressKit.pdf.

_____. *Apollo 17 Mission Report, JSC-07904*. March 1973. Accessed February 21, 2019.

https://www.hq.nasa.gov/alsj/a17/A17_MissionReport.pdf.

_____. *Apollo 17 Press Kit, Release no. 72-220K*. November 1972. Accessed December 28, 2018.

https://history.nasa.gov/alsj/a17/A17_PressKit.pdf.

_____. *Apollo Program Summary Report (JSC-09423)*. Houston, TX: Lyndon B. Johnson Space Center, April 1975. Accessed February 22, 2019. <https://www.hq.nasa.gov/alsj/APSR-JSC-09423.pdf>.

_____. "The Apollo Missions." Accessed November 1, 2018.

https://www.nasa.gov/mission_pages/apollo/missions/index.html.

_____. "LRV Flight Model Delivery." Kennedy Space Center News Release, KSC-41-71, March 10, 1971. Accessed November 8, 2018. [Page 13 of PDF]

https://www.nasa.gov/centers/kennedy/pdf/744322main_1971.pdf.

_____. "NASA Image and Video Library." Accessed November 1, 2018. <https://images.nasa.gov/> [Pre-mission artists' renderings and NASA images before and during each mission.]

_____. "NASA Selects Teams to Study Untouched Moon Samples," March 11, 2019. Accessed March 15, 2019. <https://www.nasa.gov/feature/nasa-selects-teams-to-study-untouched-moon-samples>.

- _____. "NASA Unveils Sustainable Campaign to Return to the Moon, on to Mars." September 18, 2018. Accessed March 15, 2019. <https://www.nasa.gov/feature/nasa-unveils-sustainable-campaign-to-return-to-moon-on-to-mars>.
- NASA, Goddard Space Flight Center, and Arizona State University. Lunar Reconnaissance Orbiter: Apollo Landing Sites imagery. 2009-present. Accessed January 18, 2019. https://www.lroc.asu.edu/featured_sites#ApolloLandingSites.
- NASA Space Science and Data Center. "The Apollo Program (1963-1972)." Accessed December 28, 2018. <https://nssdc.gsfc.nasa.gov/planetary/lunar/apollo.html>.
- Peizer, E. "Technical Aids." *Prosthetics and Orthotics International* 2 (1978): 105-110. Accessed January 21, 2019. http://www.oandplibrary.org/poi/pdf/1978_02_105.pdf.
- Powell, Corey S., and Laurie Gwen Shapiro. "The Sculpture on the Moon." *Slate*. December 16, 2013. Accessed January 31, 2019. http://www.slate.com/articles/health_and_science/science/2013/12/sculpture_on_the_moon_paul_van_hoeydonck_s_fallen_astronaut.html.
- Scott, David M., and Richard Jurek. *Marketing the Moon: The Selling of the Apollo Lunar Program*. Cambridge, MA: The MIT Press, 2014.
- The Seattle Times*
- McDonald, Lucile. "Farmers Take Steps to Speed Kent's Industrialization." July 8, 1956.
- "Mayor Welcomes Boeing To Kent." February 4, 1964.
- "Kent Center Gets First Employes [sic]." March 11, 1965.
- Twiss, Robert L. "Now It's Green (back) River Valley." October 24, 1965.
- Twiss, Robert L. "4,000 at Dedication of Boeing Space Center." October 30, 1965.
- "Boeing Rolls Out Version of Lunar Unit." December 23, 1970.
- "Boeing On The Moon." [multiple articles] August 1, 1971.
- "Space Agency Honors Boeing Employe [sic]." October 12, 1971.
- Stein, Alan J. "Kent – A Thumbnail History." *HistoryLink.org Online Encyclopedia of Washington State History, Essay #3587, 2001*. Accessed November 28, 2018. <http://historylink.org/File/3587>.
- Stiles, Marc. "Boeing Selling 72 Acres in Kent to IDS for Warehouses." *Puget Sound Business Journal*, December 11, 2012. Accessed March 15, 2019. <https://www.bizjournals.com/seattle/news/2012/12/11/california-company-plans-large.html>.
- von Braun, Wernher. "Crossing the Last Frontier." *Collier's Weekly*, March 22, 1952, pp. 24-29.
- _____. "How We'll Travel on the Moon." *Popular Science* 184, No. 2 (February 1964): 18-26. Accessed October 15, 2018. <https://books.google.com/books?id=qSODAAAAMBAJ&pg=PA18#v=onepage&q&f=false>.

Bibliography (continued)

_____ and Fred L. Whipple. "Man on the Moon: The Exploration." *Collier's Weekly*, October 25, 1952, pp. 38-45.

_____. "Man on the Moon: The Journey." *Collier's Weekly*, October 18, 1952, pp. 52-55.

Winch, John (Retired Engineer, LRV Program, Boeing). "Bring the Moon to Downtown Kent." Interview by Michelle Wilmot and Edgar Riebe, City of Kent, May 14, 2018. Accessed October 15, 2018. <https://vimeo.com/272473790>.

Zimbelman, James R. "The Apollo Landing Sites – Slide Set." Lunar and Planetary Institute website. Accessed December 28, 2018. <https://www.lpi.usra.edu/publications/slidesets/apollolanding/>.